

## PrEN 15193: Energy performance of buildings — Energy requirements for lighting

*Energetische Bewertung von Gebäuden — Energtische Anforderungen an die Beleuchtung — Teil 1: Abschätzung des Energiebedarfs für die Beleuchtung*

*Performance energetique des batiments — Exigences exigences energetiques pour l'eclairage — Partie 1: Estimation energetique de l'eclairage*

ICS:

Descriptors:

Document type: European Standard  
Document subtype:  
Document stage: Formal Vote  
Document language: E

# Contents

Page

Foreword.....	4
Introduction .....	5
1 Scope.....	7
2 Normative references .....	7
3 Terms and definitions.....	7
4 Calculating energy used for lighting.....	10
4.1 Total energy used for lighting .....	10
4.1.1 Total estimated energy .....	10
4.1.2 Total annual energy used for lighting.....	11
4.2 Lighting energy numeric indicator ( <i>LEN</i> ) .....	11
5 Metering .....	11
5.1 General.....	11
5.2 Load segregation .....	12
5.3 Remote metering.....	12
6 Calculation of lighting energy in buildings .....	12
6.1 Installed lighting power .....	12
6.1.1 General.....	12
6.1.2 Luminaire .....	12
6.1.3 Luminaire power ( $P_l$ ) .....	12
6.1.4 Parasitic powers ( $P_{ci}$ and $P_{ei}$ ) .....	12
6.2 Calculation methods.....	12
6.2.1 Quick method .....	12
6.2.2 Comprehensive method .....	13
6.2.3 Determination of constant illuminance factor $F_c$ .....	15
7 Benchmark of Lighting energy requirements .....	15
8 Lighting design and practice .....	15
Annex A (informative) Metering of Lighting circuit.....	17
Annex B (informative) Measurement method of total power of Luminaires and associated Parasitic power.....	20
B.1 Introduction .....	20
B.2 Test measurement of luminaire power during normal operation .....	20
B.3 Standard test conditions .....	20
B.4 Electrical measuring instruments .....	20
B.5 Test luminaires.....	20
B.6 Test voltage .....	20
B.7 Luminaire power ( $P_l$ ).....	21
B.8 Luminaire parasitic power with lamps off ( $P_{pi}$ ) .....	21
B.9 Emergency lighting luminaire parasitic input power ( $P_{ei}$ ) .....	21
B.10 Lighting controls standby parasitic power ( $P_{ci}$ ).....	21
B.11 Default luminaire power for existing lighting installations.....	21
B.12 Default parasitic energy for existing lighting installations.....	21
Annex C (informative) Determination of the Daylight Dependency Factor $F_{D,n}$ .....	22
C.1 General.....	22
C.2 Building segmentation: Spaces benefiting from daylight .....	24
C.3 Daylight Supply .....	26
C.3.1 Vertical Facades.....	26
C.3.2 Rooflights .....	36

C.4	Daylight dependent artificial lighting control, $F_{D,c}$ .....	52
C.5	Monthly Method.....	52
Annex D	(informative) Determination of occupancy dependency factor $F_o$ .....	54
D.1	Default value.....	54
D.2	Detailed determination of $F_o$ .....	54
D.3	Motivation for the choice of $F_o$ functions.....	59
Annex E	(informative) Determination of the constant illuminance factor $F_c$ .....	61
E.1	Introduction .....	61
E.2	Power for constant illuminance factor.....	61
E.3	Constant illuminance factor ( $F_c$ ).....	61
Annex F	(informative) Benchmark values and lighting design criteria.....	63
Annex G	(informative) Default values .....	66
G.1	The default values for annual operating hours relating to building type are given in Table G.1.....	66
Annex H	(informative) Other considerations .....	68
H.1	Individual dimming .....	68
H.2	Algorithmic lighting .....	68
H.3	Light pipes .....	68
H.4	Lighting installations with Scene Setting.....	69
H.5	Daylight Guidance.....	69
H.5.1	Vertical facades.....	69
H.5.2	Rooflights .....	70
Annex I	(informative) Symbols and their definitions .....	73
Annex ZA	(informative) Relationship between this European Standard and the Essential Requirements of EU Directive 2002/91/EC of THE EUROPEAN PARLIAMENT AND OF THE COUNCIL of 16 December 2002 on the energy performance of buildings .....	77
Bibliography	.....	78

## Foreword

This document (prEN 15193:2006) has been prepared by Technical Committee CEN/TC 169 "*Light and Lighting*", the secretariat of which is held by DIN.

This document is currently submitted to the CEN for final vote.

## Introduction

This European standard was devised to establish conventions and procedures for the estimation of energy requirements of lighting in buildings, and to give a methodology for a numeric indicator of energy performance of buildings. It also provides guidance on the establishment of notional limits for lighting energy derived from reference schemes.

Having the correct lighting standard in buildings is of paramount importance and the convention and procedures assume that the designed and installed lighting scheme conforms to good lighting practices. For new installations the design will be to EN 12464-1, Light and Lighting – Lighting of work places – Part 1: Indoor work places.

The standard also gives advice on techniques for separate metering of the energy used for lighting that will give regular feedback on the effectiveness of the lighting controls.

The methodology of energy estimation not only provides values for the numeric indicator but will also provide input for the heating and cooling load impacts on the combined total energy performance of building indicator.

Figure 1 gives an overview of the methodology and the flow of the processes involved.

The methodology and format of the presentation results would satisfy the requirements of the EC Directive on Energy Performance of Buildings 2002/91/EC.

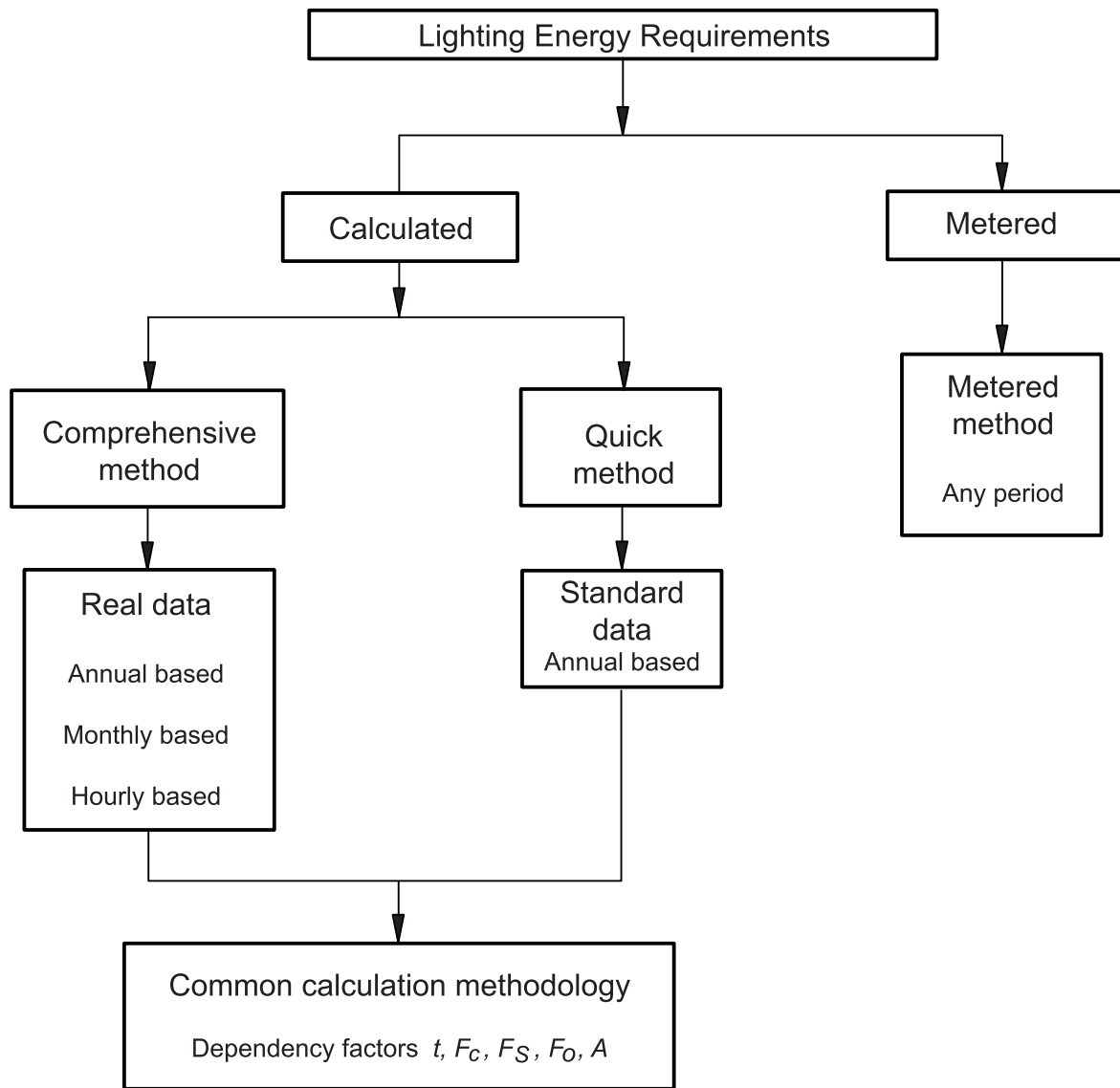

Figure 1 — Flow chart illustrating alternative routes to determine energy use

## 1 Scope

This standard specifies the calculation methodology for the evaluation of the amount of energy used for indoor lighting inside the building and provides a numeric indicator for lighting energy requirements used for certification purposes. This standard can be used for existing buildings and for the design of new or renovated buildings. It also provides reference schemes to base the targets for energy allocated for lighting usage. This standard also provides a methodology for the calculation of instantaneous lighting energy use for the estimation of the total energy performance of the building. Parasitic powers not included in the luminaire are excluded.

In this standard, the buildings are classified in the following categories: Offices, Education buildings, Hospitals, Hotels, Restaurants, Sports facilities, Wholesale and retail services and Manufacturing factories.

In some locations outside lighting may be fed with power from the building. This lighting may be used for illumination of the facade, open-air car park lighting, security lighting, garden lighting, etc. These lighting systems may consume significant energy and if they are fed from the building, this load will not be included in the Lighting Energy Numeric Indicator or into the values used for heating and cooling load estimate. If metering of the lighting load is employed, these loads may be included in the measured lighting energy.

## 2 Normative references

The following referenced documents are indispensable for the application of this document. For dated references, only the edition cited applies. For undated references, the latest edition of the referenced document (including any amendments) applies.

EN 60598, *Luminaires*

EN 60570, *Electrical supply track systems for luminaires*

EN 61347, *Lamp control gear*

EN 12193, *Light and lighting — Sports Lighting*

EN 12464-1, *Light and lighting — Lighting of work places — Part 1: Indoor work places*

EN 13032-1, *Lighting applications — Measurement and presentation of photometric data of lamps and luminaires — Part 1: Measurement and file format*

EN 1838, *Lighting applications — emergency lighting*

## 3 Terms and definitions

For the purposes of this European Standard, the following terms and definitions apply.

### 3.1

#### **built-in luminaires**

the fixed luminaires installed to provide illumination in the building

### 3.2

#### **control gear**

components required to control the operation of the lamp(s)

### 3.3 power

#### 3.3.1 luminaire power ( $P_l$ )

electrical power from the mains supply consumed by the lamp(s), control gear and control circuit in or associated with the luminaire, measured in watts which includes any parasitic power when the luminaire is turned on.

NOTE The rated luminaire power ( $P_l$ ) for a specific luminaire may be obtained from the luminaire manufacturer.

#### 3.3.2 total installed lighting power in the room or zone ( $P_n$ )

power of all luminaires in the room or zone, measured in watts

$$P_n = \sum_i P_{li} \text{ [W]} \quad (1)$$

#### 3.3.3 parasitic power

##### 3.3.3.1 luminaire parasitic power ( $P_{pi}$ )

electrical power from the mains supply consumed by the charging circuit of emergency lighting luminaires and the standby power for automatic controls in the luminaire when lamps are not operating, measured in watts

$$P_{pi} = P_{ci} + P_{ei} \text{ [W]} \quad (2)$$

##### 3.3.3.2 parasitic power of the controls only during the time with the lamps off ( $P_{ci}$ )

parasitic input power to the control system in the luminaire during the period with lamps not operating, measured in watts

##### 3.3.3.3 emergency lighting charging power ( $P_{ei}$ )

input power to the charging circuit of emergency luminaires, measured in watts

#### 3.3.4 total installed parasitic power of the controls in the room or zone ( $P_{pc}$ )

input power of all control systems in luminaires in the room or zone, measured in watts

$$P_{pc} = \sum_i P_{ci} \text{ [W]} \quad (3)$$

#### 3.3.5 total installed charging power of the emergency lighting luminaires in the room or zone ( $P_{em}$ )

input charging power of all emergency lighting luminaires in the room or zone, measured in watts

$$P_{em} = \sum_i P_{ei} \text{ [W]} \quad (4)$$



## 3.4 Energy

### 3.4.1

#### **total energy used for lighting ( $W_t$ )**

energy consumed in period  $t$ , by the luminaires when operating, and parasitic loads when the luminaires are not operating, in a room or zone, measured in kWh

### 3.4.2

#### **energy consumption used for illumination ( $W_{L,t}$ )**

energy consumed in period  $t$ , by the luminaires to fulfil the illumination function and purpose in the building, measured in kWh

### 3.4.3

#### **luminaire parasitic energy consumption ( $W_{P,t}$ )**

parasitic energy consumed in period  $t$ , by the charging circuit of emergency lighting and by the standby control system controlling the luminaires, measured in kWh

## 3.5 time

### 3.5.1

#### **operating time ( $t$ )**

the time period for the energy consumption in hours [h]

### 3.5.2

#### **annual operating time ( $t_o$ )**

annual number of operating hours of the lamp(s) and luminaires with the lamps on

$$t_o = t_D + t_N \text{ [h]} \quad (5)$$

NOTE This number is determined depending on the building use.

### 3.5.3

#### **standard year time ( $t_y$ )**

time taken for one standard year to pass, taken as 8 760 h

### 3.5.4

#### **daylight time usage ( $t_D$ )**

operating hours during the daylight time, measured in hours

### 3.5.5

#### **non-daylight time usage ( $t_N$ )**

operating hours during the non-daylight time, measured in hours

### 3.5.6

#### **emergency lighting charge time ( $t_e$ )**

operating hours during which the emergency lighting batteries are being charged in hours

### 3.5.7

#### **scene setting operation time ( $t_s$ )**

operating hours of the scene setting controls in hours

## 3.6

#### **useful area ( $A$ )**

floor area inside the outer walls excluding non-habitable cellars and un-illuminated spaces, measured in m<sup>2</sup>

### 3.7 dependency factors

#### 3.7.1

##### **daylight dependency factor ( $F_D$ )**

factor relating the usage of the total installed lighting power to daylight availability in the room or zone

#### 3.7.2

##### **occupancy dependency factor ( $F_O$ )**

factor relating the usage of the total installed lighting power to occupancy period in the room or zone

#### 3.7.3

##### **absence factor ( $F_A$ )**

factor relating to the period of absence of occupants

#### 3.7.4

##### **constant illuminance factor ( $F_C$ )**

factor relating to the usage of the total installed power when constant illuminance control is in operation in the room or zone

### 3.8

#### **maintenance Factor ( $MF$ )**

the ratio of the average illuminance on the working plane after a certain period of use of a lighting installation to the initial average illuminance obtained under the same conditions for the installation

NOTE CIE 97 gives further information

### 3.9

#### **Lighting Energy Numeric Indicator ( $LENI$ )**

the lighting energy numeric indicator ( $LENI$ ) is a numeric indicator of the total annual lighting energy required in the building

NOTE The  $LENI$  can be used to make direct comparisons of the lighting energy used in buildings that have similar functions but are of different size and configuration.

## 4 Calculating energy used for lighting

### 4.1 Total energy used for lighting

#### 4.1.1 Total estimated energy

The total estimated energy required for a period in a room or zone shall be estimated by the equation:

$$W_t = W_{L,t} + W_{P,t} \text{ [kWh]} \quad (6)$$

Where:

An estimate of the lighting energy required to fulfil the illumination function and purpose in the building ( $W_{L,t}$ ) shall be established using the following equation:

$$W_{L,t} = \sum \{ (P_n \times F_c) \times [(t_D \times F_o \times F_D) + (t_N \times F_o)] \} / 1000 \text{ [kWh]} \quad (7)$$

An estimate of the parasitic energy ( $W_{P,t}$ ) required to provide charging energy for emergency lighting and for standby energy for lighting controls in the building shall be established using the equation

$$W_{P,t} = \sum \{ \{ P_{pc} \times [t_y - (t_D + t_N)] \} + (P_{em} \times t_{em}) \} / 1000 \text{ [kWh]} \quad (8)$$

NOTE 1 The total lighting energy can be estimated for any required period  $t$  (hourly, daily, weekly, monthly or annually) in accordance with the time interval of the dependency factors used.

NOTE 2 For existing buildings,  $W_{pi}$  and  $W_{Li}$  can be established more accurately by directly and separately metering the energy supplied to the lighting (see clause 5).

NOTE 3 This estimation does not include the power consumed by control systems remote from the luminaire and not drawing power from the luminaire. Where known this should be added.

NOTE 4 Equation (8) does not include the power consumed by a central battery emergency lighting system.

#### 4.1.2 Total annual energy used for lighting

$$W = W_L + W_P \text{ [kWh/year]} \quad (9)$$

Where:

An estimate of the annual lighting energy required to fulfil the illumination function and purpose in the building ( $W_L$ ) and annual parasitic energy ( $W_P$ ) required to provide charging energy for emergency lighting and for standby energy for lighting controls in the building shall be established by equations 7 and 8 respectively.

### 4.2 Lighting energy numeric indicator (*LENI*)

Lighting Energy Numeric Indicator for the building

$$LENI = W/A \text{ [kWh/(m}^2 \times \text{year)]} \quad (10)$$

Where

$W$  is the total annual energy used for lighting [kWh/year]

$A$  is the total useful floor area of the building [m<sup>2</sup>]

## 5 Metering

### 5.1 General

The lighting consumption shall be separately measured using one of the following methods:

- a) kWh meters on dedicated lighting circuits in the electrical distribution;
- b) local power meters coupled to or integrated in the lighting controllers of a lighting management system;
- c) a lighting management system that can calculate the local consumed energy and make this information available to a building management system (BMS);
- d) a lighting management system that can calculate the consumed energy per building section and make this information available in an exportable format, e.g. a spread sheet format;
- e) a lighting management system that logs the hours run, the proportionality (dimming level) and relates this to its internal data base on installed load.

NOTE The measured value may be compared with the real kilowatt hours consumption measured during commissioning of the building.

## 5.2 Load segregation

The network of a BMS/lighting management system shall provide the same function in segregation as in the power distribution.

## 5.3 Remote metering

- 1) Remote metering is recommended for buildings having completely segregated power distribution systems.
- 2) Remote metering in buildings can also be used for more intelligent (Lighting management) systems to provide data.

NOTE Annex A gives examples of metering methods.

# 6 Calculation of lighting energy in buildings

## 6.1 Installed lighting power

### 6.1.1 General

There are two forms of installed power in buildings, luminaire power and parasitic power.

Luminaire power, which provides power for functional illumination conforming to EN 12193 for lighting of Sports facilities and EN 12464-1 for lighting of Indoor work places.

Parasitic power, which provides power for lighting control systems and for charging batteries for emergency lighting in conformance with EN 1838.

### 6.1.2 Luminaire

Luminaires and electrical components of luminaires shall be designed and constructed in accordance with the relevant parts of EN 60598, EN 60570 and/or EN 61347.

### 6.1.3 Luminaire power ( $P_l$ )

The total rated power (in watts) of a specific luminaire should be obtained in accordance with Annex B.

### 6.1.4 Parasitic powers ( $P_{ci}$ and $P_{ei}$ )

Parasitic power should be obtained in accordance with Annex B.

## 6.2 Calculation methods

### 6.2.1 Quick method

When using the quick method of estimation of the annual lighting energy estimation for typical building types equation (9) shall be used.

NOTE 1 The energy requirement estimation by the Quick method will yield higher *LENI* values than that obtained by the more accurate Comprehensive method described in 6.3.

NOTE 2 The default values for  $t_b$ ,  $t_N$ ,  $F_c$ ,  $F_D$ ,  $F_O$  and  $W_p$  are given in Annex E, F and G.

### 6.2.2 Comprehensive method

The comprehensive method allows for a more accurate determination of the lighting energy estimations for different periods e.g. annual or monthly.

When using the comprehensive method of lighting energy estimations equation (6) shall be used for the required period  $t$ .

NOTE 1 Determination of the daylight dependency factor ( $F_D$ ) for a room or zone is described in Annex C

NOTE 2 Determination of the occupancy dependency factor ( $F_O$ ) for a room or zone is described in Annex D.

NOTE 3 This method may be used for any periods and for any locations provided that the full estimation of occupancy and daylight availability is predicted.

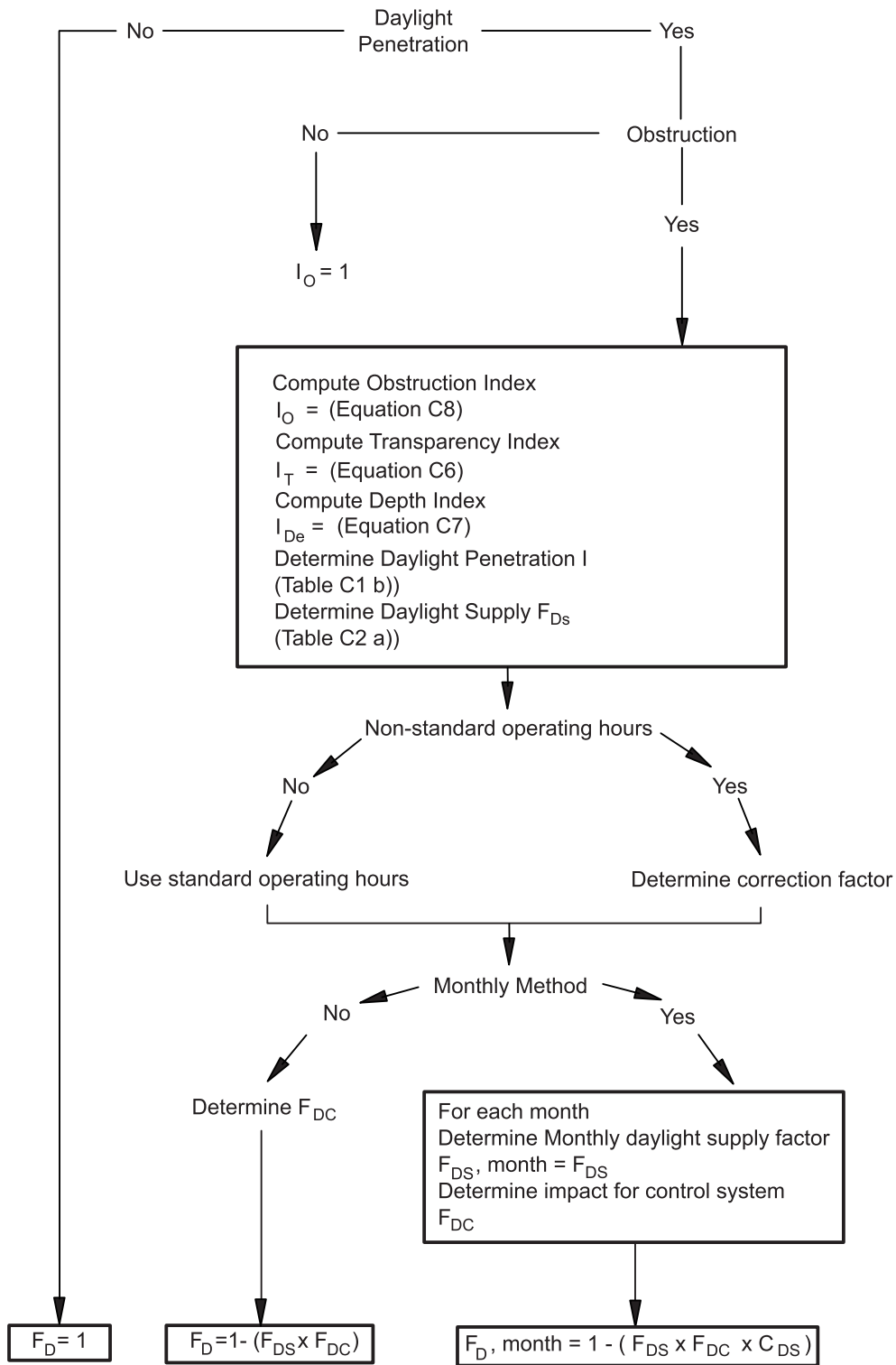

**Figure 2 — Flow chart illustrating the determination of the daylight dependency factor  $F_{D,n}$  in a zone**

### 6.2.2.1 Determination of the daylight dependency factor $F_{D,n}$

The determination of the daylight dependency factor  $F_{D,n}$  for the  $n^{\text{th}}$  room or zone should be made by the methods described in Annex C for annual and monthly time period and the process illustrated in the flow chart (Figure 2).

The daylight dependency factor  $F_{D,n}$  for room or zone in the building is determined as a function of the daylight supply factor  $F_{D,S,n}$  and the daylight dependent electric lighting control factor  $F_{D,C,n}$  and given by

$$F_{D,n} = 1 - (F_{D,S,n} \times F_{D,C,n}) \quad (11)$$

Where

$F_{D,S,n}$  is the daylight supply factor that takes into account the general daylight supply in the zone n. It represents, for the considered time interval, the contribution of daylight to the total required illuminance in the considered zone n. See Annex C, C 2.1.2 and C 2.2.2.

$F_{D,C,n}$  is the daylight control factor that accounts for the daylight depending electric lighting control system's ability to exploit the daylight supply in the considered zone n see Annex C, C.3.

NOTE 1  $F_{D,n}$  can be determined for any time period (annual, monthly or hourly). The factor has to be adjusted according to the period of the operation time at daytime  $t_b$ .

NOTE 2 Other daylight supply systems that rely on enhancements to increase or make possible daylight penetration beyond the perimeter zones are available. These are not explicitly covered in this standard but may be calculated by using daylight factors or other methods for the calculation of  $F_D$ .

NOTE 3 In zones without daylight availability,  $F_D = 1$ .

NOTE 4 The method given in Annex C can be used to consider location and climate dependent aspects of *daylight supply*.

### 6.2.2.2 Determination of occupancy dependency factor $F_{O,n}$

The occupancy dependency factor  $F_{O,n}$  for a room or zone should be determined by the methods described in Annex D.

### 6.2.3 Determination of constant illuminance factor $F_c$

The determination of the constant illuminance factor  $F_c$  for a room or zone is described in Annex E.

## 7 Benchmark of Lighting energy requirements

Benchmark data of the total lighting energy requirement estimation during the design of new or refurbished buildings should be determined from a set of default values for lighting energy requirements as provided in Annex F. The data shows the potential installed power density required for lighting the specified building types. The values are based on meeting the necessary and desired lighting criteria applied to the building. The values are average for the building and can vary substantially for different rooms or zones in the building.

## 8 Lighting design and practice

Lighting design and practice is continuously evolving and may have substantial consequences on the energy requirement for lighting. A number of these influencing factors have been considered and described in Annex H under the following headings:

- Individual dimming

A lighting control system used locally to work places to provide individual lighting comfort by adjustment to meet personal preferences.

- **Algorithmic light**  
A lighting system to take non-visual biological effects into account by automatic changing of light level, direction and colour temperature.
- **Light pipes**  
Light pipes are reflective tubes that direct sunlight and daylight from apertures in the building roof to luminaires in the interior.
- **Lighting installations with scene setting**  
A lighting system that permits pre-setting of various illumination scenes in time and location for different activities in a room or zone.
- **Daylight guidance**  
Energy savings may be obtained by employing daylight-guiding systems, that also allow the penetration of sufficient amounts of daylight into deeper spaces, whilst maintaining control of glare and overheating.



## Annex A (informative)

### Metering of Lighting circuit

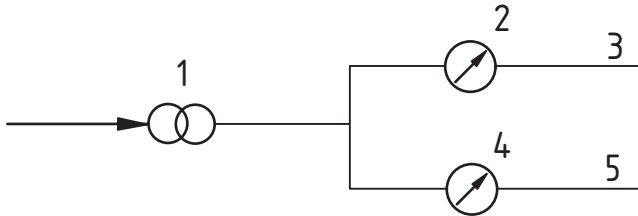

#### Key

- 1. Primary power
- 2. kWh meter other circuits
- 3. Power circuit
- 4. kWh lighting meter
- 5. Lighting circuit

**Figure A.1 — kWh meters on dedicated lighting circuits in the Electrical distribution**

In the example of Figure A.1, the kWh meter for lighting is in parallel to the kWh meter for the rest of the electrical installation. The consumption for the total building is in this case the sum of both meters.

$$W = W_{\text{light metered}} \text{ [kWh/year]} \quad (\text{A1})$$

In the example of Figure A.2, the kWh meters for lighting distributed over the different floors are placed in series with the central kWh meter of the building. In this case the central kWh meter registers the total energy consumption including the lighting consumption.

Equation for monitoring:

$$W = W_{\text{light metered}} = \sum_{\text{all floors}} (\text{kWh @ date} - \text{kWh @ (date - 12 months)}) \text{ [kWh/year]} \quad (\text{A2})$$

Local kWh meter values (as in Figure A.2) could be read and totalled by a Building Management System. No corrections for occupancy or control types are necessary.

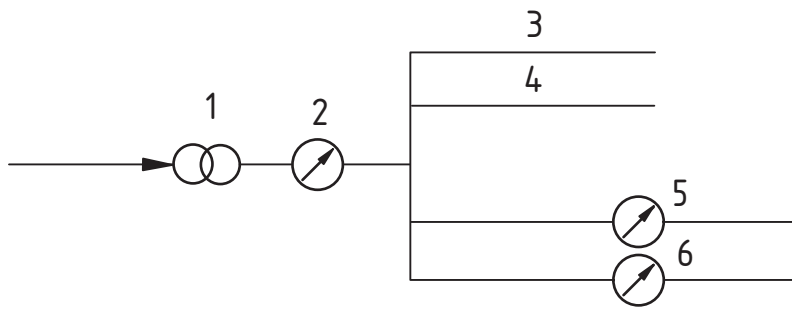

**Key**

- |                            |                                   |
|----------------------------|-----------------------------------|
| 1. Primary power           | 4. Power circuit 2                |
| 2. kWh meter – total power | 5. kWh meter – lighting circuit 1 |
| 3. Power circuit 1         | 6. kWh meter – lighting circuit 2 |

**Figure A.2 — Building with segregation of lighting circuits per floor and separately measured**

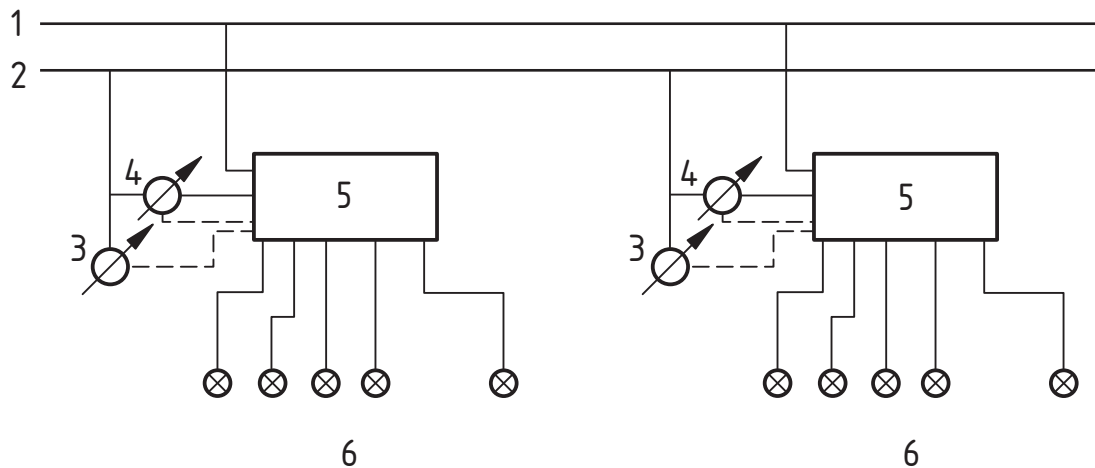

**Key**

- |                   |                     |
|-------------------|---------------------|
| 1. Bus line       | 4. Ampere meter     |
| 2. 230 volt power | 5. Light controller |
| 3. Volt meter     | 6. Luminaires       |

**Figure A.3 — Volt and ampere meters coupled to the inputs of the lighting controllers**

NOTE Some systems include a power factor meter.

Local power meters coupled to or integrated in the lighting controllers of a lighting management system. Information on the local consumed energy is made available to a building management system.

In Figure A.3, volt and ampere meters or watt meters are put on the power input of every lighting controller. The individual lighting controllers calculate the local consumed energy by integrating these values over time.

These values are made available via the bus line to either the central computer of the lighting system or the central computer of the building management system. The central computer can process this

information and present the consumed energy figures e.g. per area per month and/or for the total lighting of the building over a period of 12 months in an exportable format, such as a spread sheet.

Formula for monitoring:

$$W = W_{\text{light metered}} = \sum_{\text{all controllers}} \sum_{12 \text{ months}} (\text{kWh}_{\text{local}}) \quad [\text{kWh/year}] \quad (\text{A3})$$

NOTE 1 Energy consumption of luminaires not controlled by the lighting control system is not measured.

NOTE 2 Energy consumption of luminaires indirectly controlled via external contactors is not measured.

A lighting management system should log the hours run, the proportionality (dimming level) and relate this to its internal data base on installed load. The lighting management system makes this information available to a BMS for further reporting, or it can give the information in an exportable format.

The lighting controller sums the time per lighting load proportionally per output and makes these values available via the bus line.

NOTE 3 Energy consumption of luminaires not controlled by the lighting control system is not measured.

NOTE 4 Energy consumption of luminaires indirectly controlled via external contactors is measured.

## **Annex B**

(informative)

### **Measurement method of total power of Luminaires and associated Parasitic power**

#### **B.1 Introduction**

The values of rated luminaire input power and the rated parasitic input power should be used in the calculation of the energy performance of the building with respect to lighting requirements. The rated power values should be rounded to the nearest whole number for 10 W and above and should be to two significant figures when below 10 W. Both should be within a tolerance of  $\pm 5\%$  of the claimed value.

#### **B.2 Test measurement of luminaire power during normal operation**

The object of the test is to measure the luminaire total input power during normal operation and the associated parasitic power (the standby input power for controls, sensing devices and charge power for emergency lighting circuits) at standard reproducible conditions that are close to the conditions of service for which the luminaire is designed. Ideally, these luminaire electrical measurements should be made during photometric tests.

#### **B.3 Standard test conditions**

Test conditions for photometric measurements should be in accordance with EN 13032-1 sections 5.1, 5.2 and 5.3.

#### **B.4 Electrical measuring instruments**

Voltmeters, ampere meters and wattmeter's should conform to the requirements for Class Index 0.5 or better (precision grade).

#### **B.5 Test luminaires**

The luminaire should be representative of the manufacturer's regular product. The luminaire should be mounted in the position in which it is designed to operate.

#### **B.6 Test voltage**

The test voltage at the supply terminals to the luminaire should be the rated voltage of the luminaire in accordance with EN 13032-1 section 5.2.2.

## **B.7 Luminaire power ( $P_i$ )**

The luminaire power  $P_i$ , should be the value obtained in accordance with B1 to B6 or as declared by the manufacturer. The value should include losses in all lamp(s), ballast(s) and other component(s), for normal full output operating mode or at maximum light output if the luminaire includes a dimming control gear.

## **B.8 Luminaire parasitic power with lamps off ( $P_{pi}$ )**

The luminaire parasitic power  $P_{pi}$  should be the declared rated power of the luminaire for the luminaire operating in standby mode only. For controlled luminaires this is the power to the detectors, for emergency luminaires this is the steady state power for charging the batteries.

## **B.9 Emergency lighting luminaire parasitic input power ( $P_{ei}$ )**

The luminaire parasitic power  $P_{ei}$  for charging the batteries in emergency luminaires should be the declared rated power of the luminaire for the self-contained luminaire operating in battery charge mode only.

## **B.10 Lighting controls standby parasitic power ( $P_{ci}$ )**

The luminaire parasitic power  $P_{ci}$  for standby operation of the lighting controls and detectors without operating the lamps should be the declared rated parasitic power of the luminaire.

## **B.11 Default luminaire power for existing lighting installations**

In existing buildings where the luminaire power ( $P_i$ ) is not known this power can be estimated as:

- a) (the lamp rated power)  $\times$  (number of lamps in the luminaire) for lamps operating directly on mains supply voltage e.g. mains voltage incandescent lamps, self ballasted fluorescent lamps, etc.
- b)  $1.2 \times$  (the lamp rated power)  $\times$  (number of lamps in the luminaire) for lamps connected to the mains supply via a ballast or transformer in the luminaire.

## **B.12 Default parasitic energy for existing lighting installations**

In existing buildings where the parasitic energy consumed is not known this annual energy can be estimated to consist of  $1 \text{ kWh}/(\text{m}^2 \times \text{year})$  for emergency lighting and  $5 \text{ kWh}/(\text{m}^2 \times \text{year})$  for the automatic lighting controls if used. (total is  $W_p = 6 \text{ kWh}/(\text{m}^2 \times \text{year})$ ).

## Annex C (informative)

### Determination of the Daylight Dependency Factor $F_{D,n}$

#### C.1 General

This appendix specifies a simplified approach for determining  $F_{D,S,n}$  and  $F_{D,C,n}$  and therefore  $F_{D,n}$ . Vertical facades with fenestration and rooflight solutions are considered. The method can be applied on an annual and on a monthly basis.

In accordance with subclause 6.2.2.1, the daylight dependency factor  $F_{D,n}$  is determined as a function of the daylight supply factor  $F_{D,S,n}$  and the daylight dependent artificial lighting control factor  $F_{D,C,n}$ .

Therefore:

$$F_{D,n} = 1 - (F_{D,S,n} \times F_{D,C,n}) \quad (C1)$$

The procedure illustrated in Figure C.1 incorporates the following 5 Steps:

- 1) Segmentation of the building into zones with and without daylight access.
- 2) Determination of the impact of room parameters, facade geometry, and outside obstruction on the daylight penetration into the interior space using the concept of the daylight factor.
- 3) Prediction of the energy saving potential described by the daylight supply factor  $F_{D,S,n}$  as a function of local climate, maintained illuminance and daylight factor.
- 4) Determination of the exploitation of the available daylight by the type of lighting control by the daylight control factor  $F_{D,C,n}$ .
- 5) Conversion of annual value  $F_{D,n}$  to monthly values.

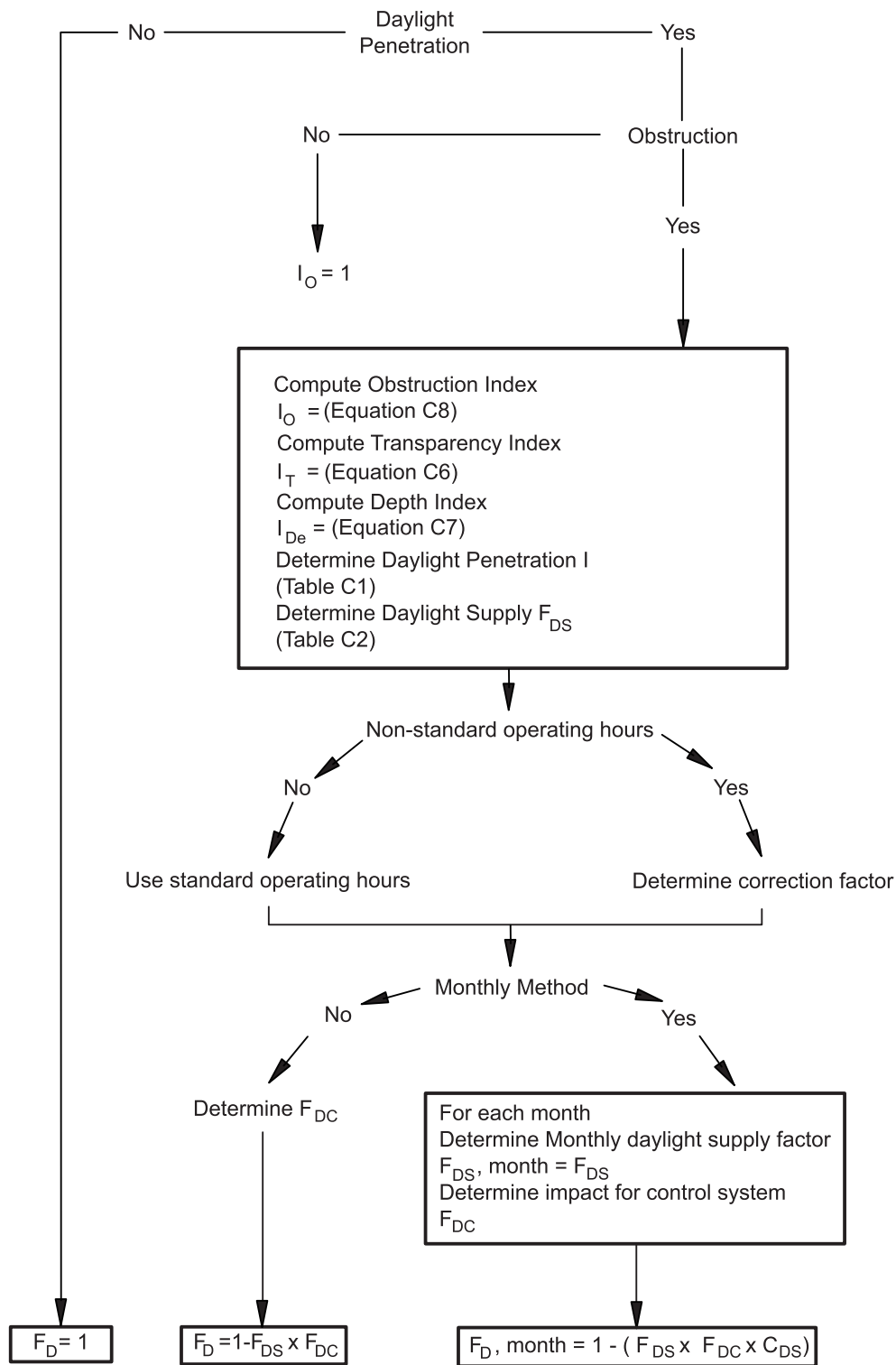

**Figure C.1 — Flow chart illustrating the determination of the daylight dependency factor  $F_{D,n}$  in a zone**

## C.2 Building segmentation: Spaces benefiting from daylight

Spaces have to be sub-divided into a daylight zone  $A_{D,j}$  and a zone  $A_{ND,j}$  not receiving any daylight. If a zone receives daylight from several façades or roof lights, the more favourable case may be assumed for the superimposed daylighting zone (for the sake of simplicity). Alternatively, it is also permissible to superimpose the daylight factor that is used to classify the daylight supply exclusively for the respective type of daylight aperture (façade or roof light) following sections C.3.1 and C.3.2.

### *Daylight area – vertical façades*

The maximum possible depth of zone  $A_{D,j}$  that receives daylight through façades results as follows:

$$a_{D,max} = 2.5 \cdot (h_{Li} - h_{Ta}). \quad [m] \quad (C.2)$$

where

$a_{D,max}$  maximum depth of daylight zone [m]

$h_{Li}$  height of lintel above floor [m]

$h_{Ta}$  height of task area (reference plane) above floor. [m]

Here, the maximum depth of the daylight zone  $a_{D,max}$  is calculated from the interior surface of the exterior wall, perpendicular towards the façade considered. If the actual depth of the zone of calculation is smaller than the calculated maximum depth of the daylight zone, the space depth can be taken as the depth of the daylight zone  $a_D$ . If the actual depth of the space is less than 1.25 times the calculated maximum depth, the real depth of the space of calculation can be used for  $a_D$ .

Thus, the sub-area  $A_{D,j}$  of the daylight space j results as follows:

$$A_{Dj} = a_D \cdot b_D, [m^2] \quad (C3)$$

where

$a_D$  depth of daylight zone [m]

$b_D$  width of daylight zone. [m]

Usually, the width of the daylight zone  $b_D$  corresponds to the interior width of the façade of the building zone or of the sector of calculation. Internal walls may be neglected. If windows are located only in parts of the façade, the width of the daylight zone allocated to this façade corresponds to the width of the façade section containing windows, plus half the depth of the daylight zone. The geometric relations are illustrated in Figure C.2 and C.3.



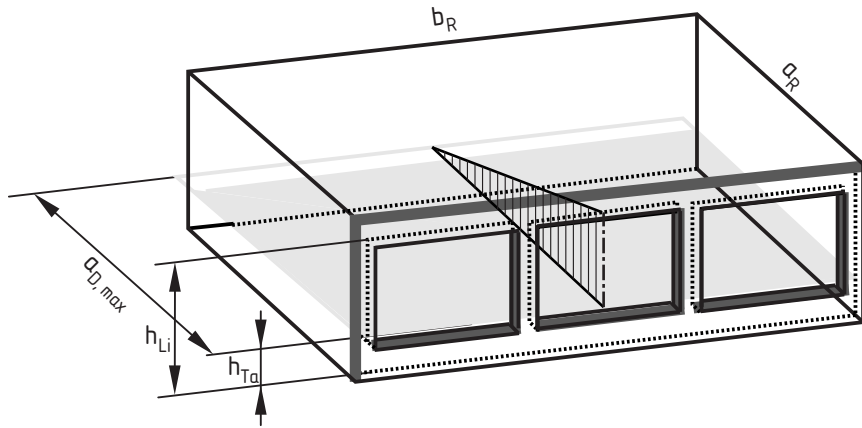

Figure C.2 — Large façade opening with moderate room depth

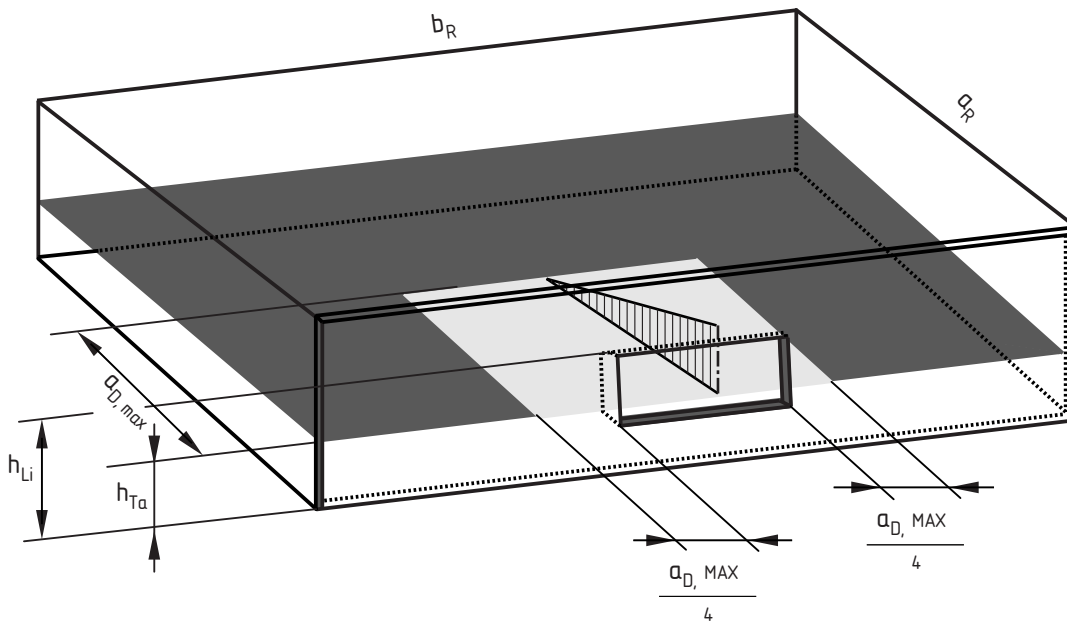
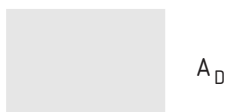

Figure C.3 — Small façade opening with larger room depth



### Daylight zones – roof lights

As a rule, the task areas directly underneath roof lights that are uniformly distributed across the roof surface are treated as daylit zones. In case of single roof lights and for zones bordering sectors of uniformly distributed roof lights, those sub-zones of the task area are assumed to be daylit that are located within a distance defined by  $a_{D,max}$

$$a_{D,max} \leq (h_R - h_{Ta}) \text{ towards the next edge of a roof light. [m]} \quad (C4)$$

Where

$$h_R \text{ clear room height of the space of calculation with roof light. [m]}$$

For surfaces within the space of calculation not receiving any daylight:  $F_D = 1$ . (C.5)

### Differentiation between vertical façade and roof light

In cases of doubt whether an aperture should be treated as a window or a roof light, any apertures where the glazed parts are located entirely above the room's ceiling, are to be classified as roof lights.

## C.3 Daylight Supply

### C.3.1 Vertical Facades

The daylight supply  $F_{DS,n}$  is evaluated separately for vertical facades and rooflights.

#### C.3.1.1 Daylight Factor Classification

Daylight supply of a zone benefiting from daylight depends on the geometric boundary conditions described by the transparency index  $I_T$ , the depth index  $I_{De}$ , and the obstruction index  $I_O$ .

#### A. Transparency index $I_T$

The transparency index  $I_T$  of the part of the building, which can benefit from daylight, is defined by:

$$I_T = A_C / A_D \quad (C6)$$

where

$$A_C \text{ area of the facade opening (carcass opening) of the considered space. [m}^2\text{]}$$

$$A_D \text{ Total area of horizontal work planes benefiting from natural lighting. [m}^2\text{]}$$

#### B. Depth index $I_{De}$

##### Vertical facades

The depth index  $I_{De}$  of the space, which can benefit from natural lighting  $I_{De}$  is defined by:

$$I_{De} = a_D / (h_{Li} - h_{Ta}) \quad (C7)$$

NOTE where a zone has daylight from more than one facade, further guidance is given in C.2.

### C. Obstruction Index $I_o$

The obstruction index  $I_o$  accounts for effects reducing light incident onto the façade. Examples of obstruction:

- by other buildings and natural obstacles such as trees and mountains;
- the building itself including simple courtyard and atrium designs;
- horizontal and vertical overhangs attached to the façade;
- and glazed double facades.

The obstruction index  $I_o$  should be obtained using the following equation:

$$I_o = I_{o,OB} \times I_{o,OV} \times I_{o,SF} \times I_{o,CA} \times I_{o,GDF} \quad (C8)$$

NOTE if the correction factor for the courtyard and atria is less than 1, then the correction factor for linear obstructions  $I_{o,OB} = 1$ .

$I_o$  is the correction factor Obstruction

$I_{o,OB}$  is the correction factor for linear obstructions

$I_{o,OV}$  is the correction factor Overhang

$I_{o,VF}$  is the correction factor for vertical fins

$I_{o,CA}$  is the correction factor courtyard and atria

$I_{o,GDF}$  is the correction factor for glazed double facades

For simplicity the obstruction can be evaluated for a window in the middle of a façade. Obstruction influences should be averaged.

$I_{o,OB}$ ,  $I_{o,OV}$ ,  $I_{o,VF}$ ,  $I_{o,CA}$ ,  $I_{o,GDF}$  can be obtained as follows:

*Linear Obstructions*,  $I_{o,OB}$

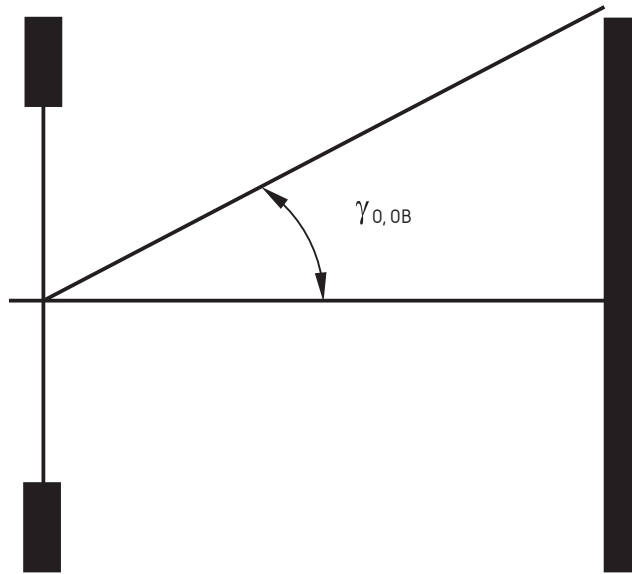

**Figure C.4 — Definition of obstruction angle  $\gamma_{0,OB}$**

In accordance with Figure C.2, the obstruction angle is determined from the middle of the considered carcass opening measured at the outer plane of the building shell. The correction factor for linear obstructions can be obtained by:

$$l_{0,OB} = \cos(1,5 \times \gamma_{0,OB}) \text{ for } \gamma_{0,OB} < 60^\circ \quad (\text{C9})$$

$$l_{0,OB} = 0 \text{ for } \gamma_{0,OB} \geq 60^\circ \quad (\text{C.10})$$

where

$\gamma_{0,OB}$  Obstruction angle ( $^\circ$ ) from horizontal in accordance with Figure C.4

NOTE Although there is daylight entry above  $60^\circ$  it has no impact on energy saving.

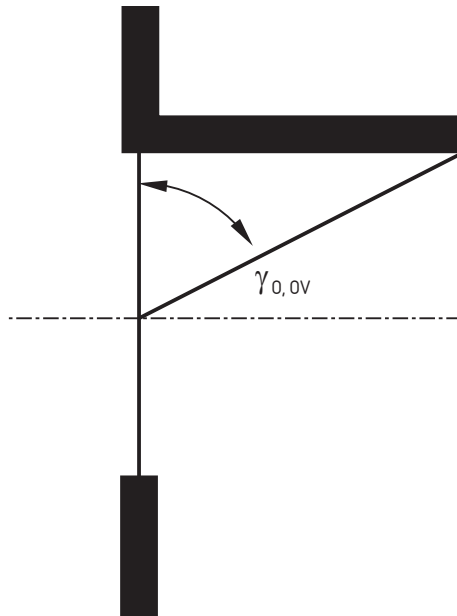

**Figure C.5 — Definition of horizontal overhang angle  $\gamma_{0,ov}$**

*Overhangs,  $l_{0,ov}$*

In accordance with Figure C.5, the horizontal overhang angle is determined from the middle of the considered carcass opening measured at the outer plane of the building shell. The correction factor for overhangs can be obtained by:

$$l_{0,ov} = \cos(1,33 \times \gamma_{0,ov}) \text{ for } \gamma_{0,ov} < 67,5^\circ \quad (\text{C11})$$

$$l_{0,ov} = 0 \text{ for } \gamma_{0,ov} \geq 67,5^\circ$$

Where

$\gamma_{0,ov}$  is the horizontal overhang angle ( $^\circ$ )

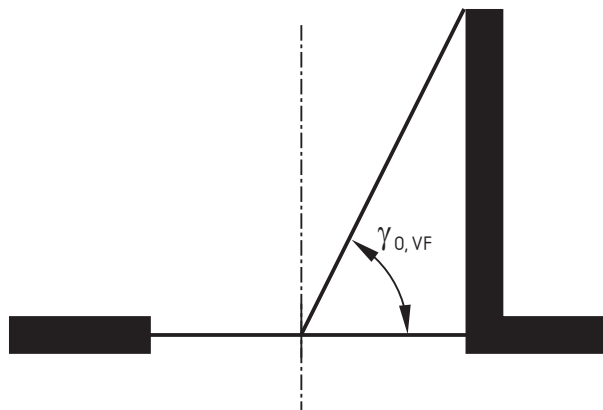

**Figure C.6 — Definition of vertical fin angle  $\gamma_{0,vf}$**

In accordance with Figure C.6, the obstruction angle for vertical fins is determined from the middle of the considered carcass opening measured at the outer plane of the building shell. The correction factor for vertical fins can be obtained by:

$$I_{O,VF} = 1 - \gamma_{O,VF}/300^\circ \quad (C12)$$

where

$\gamma_{O,VF}$  is the vertical fin angle (°)

*Courtyards and Atria,  $I_{O,CA}$*

Courtyards as well as atria are designed with many variations. This simplified model assumes 4 sided courtyards and atria. 3 sided and linear atria may provide better daylight supply in adjacent indoor spaces. This potentially better daylight situation can always be determined with more detailed methods.

The courtyard and atrium geometry is described in accordance with Figure C.7 by the well-depth index:

$$w_{_d} = h_{At}(l_{At} + w_{At}) / (2l_{At}w_{At}) \quad (C13)$$

Where:

$w_{_d}$  is the well-depth index

$h_{At}$  is the height from floor level of considered adjacent space to the top of the atrium or the courtyard in m

$l_{At}$  is the length of atrium or courtyard [m]

$w_{At}$  is the width of the atrium or courtyard [m]

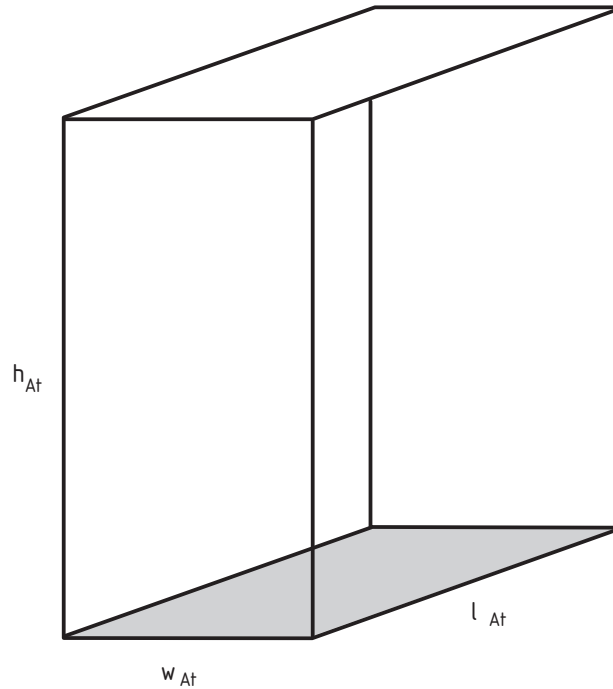

**Figure C.7 — Quantities for defining the well-depth index**

The correction factor for courtyards and atria can then be obtained by:

$$l_{O,CA} = 1 - 0.85 w_{\perp} d \quad \text{for courtyards} \quad (C14)$$

$$l_{O,CA} = \tau_{At} k_{AT,1} k_{AT,2} k_{AT,3} (1 - 0.85 w_{\perp} d) \quad \text{for atria} \quad (C15)$$

$$l_{O,CA} = 0 \quad \text{for } w_{\perp} d > 1.18$$

NOTE Although there is daylight entry it has no impact on energy saving.

Where:

$\tau_{At}$  is transmission factor of atrium glazing for normal incidence

$k_{AT,1}$  is the factor accounting for frames of atrium roof

$k_{AT,2}$  is the factor accounting for dirt on atrium roof

$k_{AT,3}$  is the factor accounting for not normal light incidence on facade (0.85, in general sufficient)

#### *Glazed double facades*

The correction factor for glazed double facades in front of the considered space can be obtained by:

$$l_{O,GDF} = \tau_{GDF} k_{GDF,1} k_{GDF,2} k_{GDF,3} \quad (C16)$$

Where:

$\tau_{GDF}$  is the transmission factor of glazed double façade

$k_{\text{GDF},1}$  is the factor accounting for frames of glazed double façade

$k_{\text{GDF},2}$  is the factor accounting for dirt of glazed double façade

$k_{\text{GDF},3}$  is the factor accounting for not normal light incidence on facade (0.85, in general sufficient)

Vertical and horizontal barriers within the façade gap can be approximated by the parameters of  $I_{O,OV}$  and  $I_{O,VF}$ . Generally the dirt on glazing within the gap of glazed double facades is negligible, such that accounting for dirt on glazing using the factor  $k_1$  (see equation C.19) for the main façade plane is sufficient. Therefore  $k_{\text{GDF},2} = 1$ . The factor accounting for the frame of the glazed double façade is:

$$k_{\text{GDF},1} = \text{light transmitting area/Carcass Opening.} \quad (\text{C17})$$

Only the part of the glazed double façade projected onto the transparent main (inner) façade plane is considered in the determination of  $k_{\text{GDF},1}$ .

#### D. Daylight factor

From the geometric indices  $I_T$ ,  $I_{De}$  and  $I_O$  the access of the zone to daylight can be estimated for the carcass facade opening:

$$D_C = (4.13 + 20.0 \times I_T - 1.36 \times I_{De}) I_O (\%) \quad (\text{C18})$$

$D_C$  is the daylight factor for carcass facade opening (i.e. without fenestration and sun-protection system).

The combination of large depth indices  $I_{De}$  and small transparency indices  $I_T$  may result - in this approximation - in values of  $D_C$  smaller than zero.  $D_C$  then should be set to zero or should be calculated with more detailed procedures.

NOTE 1 This will only occur for small daylight factors for which energy savings will be difficult to determine.

#### E. Daylight factor classification

The impact of the fenestration and shading system on the indoor lighting levels should be determined by using facade type dependent correlations of  $D_C$  with the expected energy demand, i.e. methods deriving the daylight supply factor  $F_{Ds}$  as function of the facade system. Where these dependencies are not available, a simplified estimation, correlating the fenestration properties without shading system with the expected energy demand should be calculated as follows:

$$D = D_C \tau k_1 k_2 k_3 [\%] \quad (\text{C19})$$

Where:

$D$  is the daylight factor for the zone [%]

$\tau$  is the direct. hemispherical Transmission of fenestration

$k_1$  is the factor accounting for frame of fenestration system (typically 0.7)

$k_2$  is the factor accounting for dirt on glazing (typically 0.8 but for self cleaning glazing may be as high as 1.0)

$k_3$  is the factor accounting for not normal light incidence on facade (the value of 0.85, in general sufficient for standard glazing). Table C.1a contains luminous transmittance values for some glazing materials used for vertical glazing.

Depending on how to judge the impact of the fenestration and sun-protection system, therefore using either  $D_c$  or  $D$  the daylight penetration can be rated in accordance with Table C.1b.



**Table C 1a, Typical values of the transmittance  $\tau_{D65,SNA}$  of transparent and translucent building components**

Type	$U$	$g_{\perp}$	$\tau_e$	$\tau_{D65,SNA}$
Single glazing	5,8	0,87	0,85	0,90
Double glazing	2,9	0,78	0,73	0,82
Triple glazing	2,0	0,70	0,63	0,75
low-e glazing, double glazed	1,7	0,72	0,60	0,74
low-e glazing, double glazed	1,4	0,67	0,58	0,78
low-e glazing, double glazed	1,2	0,65	0,54	0,78
low-e glazing, triple glazed	0,8	0,50	0,39	0,69
low-e glazing, triple glazed	0,6	0,50	0,39	0,69
Solar protection glazing, double	1,3	0,48	0,44	0,59
Solar protection glazing, double	1,2	0,37	0,34	0,67
Solar protection glazing, double	1,2	0,25	0,21	0,40

NOTE The data in Table C.1a is only for indication. For accurate data contact the manufacturer or supplier.

The impact of the fenestration and sun-protection system, can be judged by using either  $D_c$  or  $D$  the daylight penetration as indicated in Table C.1b.

**Table C.1b Daylight penetration as function the daylight factor.**

Classification		<b>Daylight Penetration (Access of the zone to daylight)</b>
$D_c$	$D$	
$D_c \geq 6 \%$	$D \geq 3 \%$	Strong
$6 \% > D_c \geq 4 \%$	$3 \% > D \geq 2 \%$	Medium
$4 \% > D_c \geq 2 \%$	$2 \% > D \geq 1 \%$	Weak
$D_c < 2 \%$	$1 < D \%$	None

Detailed calculation using more accurate modeling of geometric relations should be used to determine the *daylight penetration*. The reference value for the daylight factor of the considered space is the average over the centre axis of the considered area, parallel to the considered facade.

### C.3.1.2 Daylight supply factor

The daylight supply factor  $F_{D,s}$  can be approximated as a function of latitude  $\gamma_{\text{Site}}$  for latitudes ranging from 38° to 60° north by the relation

$$F_{D,s} = a + b \gamma_{\text{Site}} \quad (\text{C20a})$$

For different maintained illuminance and daylight penetration classifications the coefficients a and b are listed in Table C.2a. Figure C.8 illustrates the dependency between  $\gamma_{\text{Site}}$  and  $F_{D,s}$  for a maintained illuminance of 500 lx. Table C.2b shows the daylight supply factor  $F_{D,s}$  for selected sites across Europe. The daylight supply factor  $F_{D,s}$  is valid for a daily operation hour period of 0800 hours to 1700 hours. For longer daily day time operating periods the values should be multiplied by a correction factor of 0.7. For longer non-daylight periods during the operating time the following applies  $F_{D,s,n} = 0$ , i.e.  $F_{D,n} = 1$ . From the annual daylight supply factors, monthly values can be derived using the procedure in accordance with Clause C.4.

**Table C.2a — Coefficients for determining the daylight supply factor  $F_{D,s}$  for vertical facades as function of daylight penetration in zone n and maintained illuminance  $E_m$ .**

Maintained illuminance	Daylight penetration	a	b
[lux]			
300	weak	1.2425	-0.0117
	medium	1.3097	-0.0106
	strong	1.2904	-0.0088
500	weak	0.9432	-0.0094
	medium	1.2425	-0.0117
	strong	1.3220	-0.0110
750	weak	0.6692	-0.0067
	medium	1.0054	-0.0098
	strong	1.2812	-0.0121

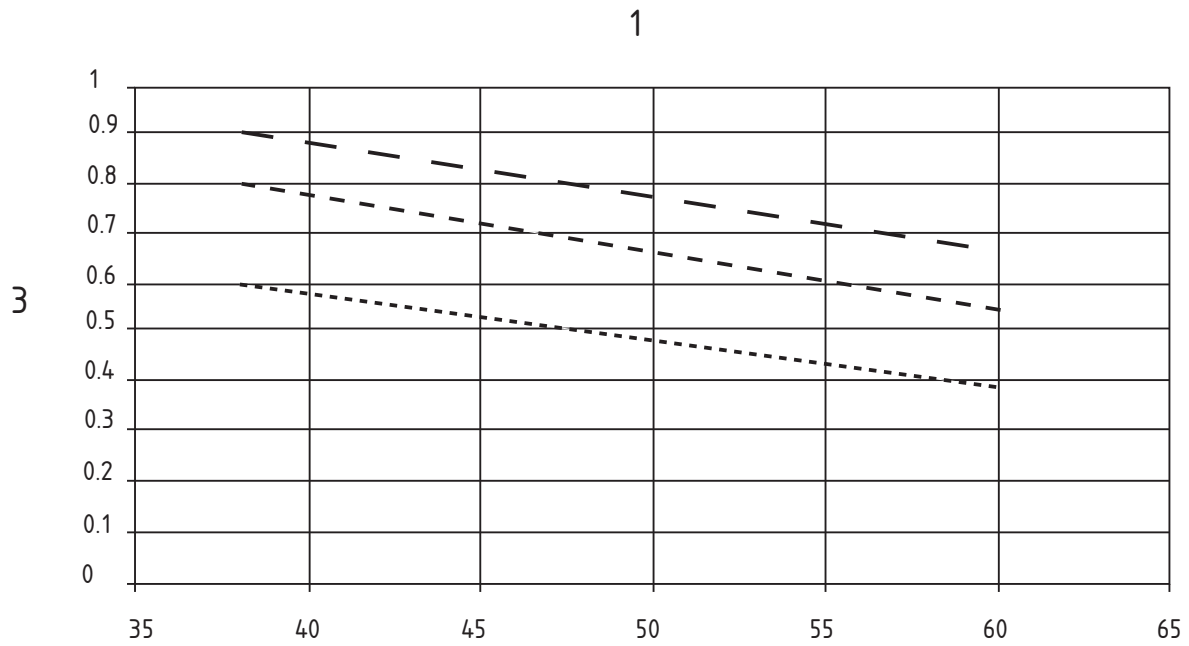

**Figure C.8 — Daylighting supply factor  $F_{DS}$  for vertical facades as function of the site latitude and daylight penetration for a maintained illuminance  $E_m$ .**

**Table C2b: Daylight supply factor  $F_{DS}$  for vertical facades as function of the daylight penetration and the maintained illuminance  $E_m$  for different sites**

Site	Latitude $\gamma$	Daylight Supply factor $F_{DS}$ ranges from 0-1								
		300 lx			500 lx			750 lx		
	[°]	weak	medium	strong	weak	medium	strong	weak	medium	strong
Athens	38	0.80	0.91	0.96	0.59	0.80	0.90	0.41	0.63	0.82
Lyon	46	0.70	0.82	0.89	0.51	0.70	0.82	0.36	0.55	0.72
Bratislava	48	0.68	0.80	0.87	0.49	0.68	0.79	0.35	0.54	0.70
Frankfurt	50	0.66	0.78	0.85	0.47	0.66	0.77	0.33	0.52	0.68
Watford	52	0.63	0.76	0.83	0.45	0.63	0.75	0.32	0.50	0.65
Gävle	60	0.54	0.67	0.76	0.38	0.54	0.66	0.27	0.42	0.56

## C.3.2 Rooflights

### C.3.2.1 Daylight Factor Classification

Analogous to the procedure for vertical facades daylight supply, this is initially determined by the daylight factor. The daylight supply factor will then be determined as a function of the daylight factor, the maintained illuminance, orientation, and tilt of the glazed roof openings.

In rooms with rooflights the mean daylight factor ( $\bar{D}_j$ ) is given by:

$$\bar{D}_j = D_{\text{ext}} \times \tau_{\text{D65}} \times k_{\text{Obl},1} \times k_{\text{Obl},2} \times k_{\text{Obl},3} \times \frac{\sum A_{\text{Rb}}}{A_{\text{RG}}} \times \eta_{\text{R}} [\%] \quad (\text{C20})$$

Where:

$A_{\text{Rb}}$  is the area of the rooflight openings (area of carcass opening) [ $\text{m}^2$ ]

$A_{\text{RG}}$  is the floor area of considered space [ $\text{m}^2$ ]

$D_{\text{ext}}$  is the external daylight factor [%]

$\tau_{\text{D65}}$  is the luminous transmittance of the scattering roof glazing

$k_{\text{Obl},1}$  is the factor for considering framing (typically 0.8)

$k_{\text{Obl},2}$  is the factor for considering dirt (typically 0.8)

$k_{\text{Obl},3}$  is the factor considering non-perpendicular light incidence (usually 0.85)

$\eta_{\text{R}}$  is the utilization factor in accordance with Table C.3a and C.3b.

This procedure is also applicable for clear glazing. Table C.3a and C.3b contains luminous transmittance values for materials used in rooflights. The data in Tables C.3a and C.3b are for indication. For accurate data contact the manufacturer or supplier.

**Table C.3a — Benchmark values for luminous transmittances  $U$ ,  $g$ ,  $\tau_{D,65}$  for different plastic glazing materials often used in rooflights**

“A” individual roof windows, glazed, “B” continuous rooflight, glazed

Type	composition	type	$U$	$g$	$\tau_{D,65}$
			[W/(m <sup>2</sup> K)]	[-]	[-]
A	Acrylic glazing, single skin	clear	5,4	0,85	0,92
	Acrylic glazing, single skin	opal	5,4	0,80	0,83
	Acrylic glazing, double skin	clear	2,7	0,78	0,80
	Acrylic glazing, double skin	opal/clear	2,7	0,72	0,73
	Acrylic glazing, triple skin	clear	1,8	0,66	0,68
	Acrylic glazing, triple skin	opal/opal/clear	1,8	0,64	0,60
B	Polycarbonate-structured-sheet, double skin, 6 mm	clear	3,6	0,86	0,82
	Polycarbonate-structured-sheet, double skin, 6 mm	opal	3,6	0,78	0,64
	Polycarbonate-structured-sheet, double skin, 8 mm	clear	3,3	0,81	0,81
	Polycarbonate-structured-sheet, double skin, 8 mm	opal	3,3	0,70	0,62
	Polycarbonate-structured-sheet, double skin, 10 mm	clear	3,1	0,85	0,80
	Polycarbonate-structured-sheet, double skin, 10 mm	opal	3,1	0,70	0,50
	Polycarbonate-structured-sheet, triple skin, 10 mm	clear	3,0	0,69	0,73
	Polycarbonate-structured-sheet, triple skin, 10 mm	opal	3,0	0,62	0,52
	Polycarbonate-structured-sheet, quadruple skin, 10 mm	opal	2,5	0,59	0,50
	Polycarbonate-structured-sheet, triple skin, 16 mm	clear	2,4	0,69	0,72
	Polycarbonate-structured-sheet, triple skin, 16 mm	opal	2,4	0,55	0,48
	Polycarbonate-structured-sheet, quintuple skin, 16 mm	opal	1,9	0,52	0,45
	Polycarbonate-structured-sheet, sextuple skin, 16 mm	opal	1,85	0,47	0,42
	Polycarbonate-structured-sheet, quintuple skin, 20 mm	clear	1,8	0,70	0,64
	Polycarbonate-structured-sheet, quintuple skin, 20 mm	opal	1,8	0,46	0,44
	Polycarbonate-structured-sheet, quadruple skin, 25 mm	clear	1,7	0,62	0,68
	Polycarbonate-structured-sheet, quadruple skin, 25 mm	opal	1,7	0,53	0,45
	Polycarbonate-structured-sheet, sextuple skin, 25 mm	clear	1,45	0,67	0,62
Polycarbonate-structured-sheet, sextuple skin, 25 mm	opal	1,45	0,46	0,44	

**Table C. 3b Benchmark values for luminous transmittances  $U$ ,  $g$ ,  $\tau_{D,65}$  for different glass type glazing materials often used in rooflights**

**“A” individual roof windows, glazed, “B” continuous rooflight, glazed**

Type	Composition	type	$U_g$ [W/(m <sup>2</sup> K)]	$g$	$\tau_{D,65}$
A	4 mm float glass 16 mm air 4 mm float glass	Clear double pane	2.8	0.79	0.81
A	4 mm toughened glass 16 mm Argon 4 mm float glass w. coating	Clear double pane Low-e	1.2	0.59	0.76
A	4 mm toughened glass 14 mm Argon 33.1 laminated float glass	Clear double pane Low-e	1.2	0.54	0.75
A	4 mm toughened 14 mm air 33.1 laminated float glass w. coating	Clear double pane Low-e, Sun protection	1.2	0.27	0.42
B	Laminated glass 6.2 16 mm air, 6 mm float glass	Clear	2.7	0.67	0.77
B	Laminated glass 6.2 16 mm air, 8 mm float glass	Clear	2.7	0.67	0.77
B	Laminated glass 6.2 16 mm air, 6 mm float glass	Clear	2.7	0.65	0.77
B	Laminated glass 8.2 16 mm air, 8 mm float glass	Clear	2.7	0.65	0.76
B	Laminated glass 10.2 16 mm air, 6 mm float glass	Clear	2.7	0.63	0.76
B	Laminated glass 10.2 16 mm air, 8 mm float glass	Clear	2.7	0.63	0.76
B	Laminated glass 6.2 16 mm argon, 6 mm float glass	Coated, silver	1.1	0.52	0.72
B	Laminated glass 6.2 16 mm argon, 8 mm float glass	Coated, silver	1.1	0.52	0.71
B	Laminated glass 8.2 16 mm argon, 6 mm float glass	Coated, silver	1.1	0.51	0.71
B	Laminated glass 8.2 16 mm argon, 8 mm float glass	Coated, silver	1.1	0.51	0.70
B	Laminated glass 10.2 16 mm argon, 6 mm float glass	Coated, silver	1.1	0.50	0.70
B	Laminated glass 10.2 16 mm argon, 8 mm float glass	Coated, silver	1.1	0.49	0.70
B	6 mm toughened glass (extra clear) 18mm Argon, 33.1 laminated float glass	Clear double pane	1.5	0.61	0.79
B	6 mm toughened glass (green) 18 mm Argon, 33.1 laminated float glass	Clear double pane	1.5	0.38	0.64
B	6 mm toughened glass (grey) 18 mm Argon, 33.1 laminated float glass	Clear double pane	1.5	0.34	0.39
B	6 mm toughened glass (extra clear) 18 mm Argon, 44.1 laminated float glass	Clear double pane	1.5	0.55	0.78

The external daylight factor  $D_{ext}$  is defined as follows:

$$D_{ext} = \frac{E_F}{E_{ext}} \quad [\%] \quad (C21)$$

Where:

$E_F$  is the illuminance on the outer surface of the rooflight in the plane of the glazing for overcast sky conditions (lux)

$E_{ext}$  is the unobstructed horizontal outdoor illuminance at overcast sky conditions (lux)

The factor for considering framing  $k_{Obl,1}$  can be obtained in a similar way as vertical facades. For individual rooflights the set of construction devices also includes upstands.  $k_{Obl,1}$  is the ratio between the light input area  $A_{Fs} = a_s \times b_s$ , i.e. the top opening of the upstand less further opaque construction elements of the individual rooflights or continuous rooflights, to the area of carcass opening  $A_{Rb} = a_{Rb} \times b_{Rb}$  in accordance with Figure C.2.

For saw tooth lighting sections (Sheds) where the carcass opening does not correspond to the intersection area of the shed body and the roof area, see Figure C.10, the area of the carcass opening is determined by  $A_{Rb} = h_G \times b_{Rb}$ , with  $h_G$  being the height of the light input area and  $b_{Rb}$  being the width of the light input area. The factor for considering the framing  $k_{Obl,1}$  takes into account further opaque construction elements in the carcass opening as defined above. Table C.4 contains the external daylight factors  $D_{ext}$  at a ground luminous reflectivity  $\rho_B$  of 0.2 for selected tilt angles of the shed glazing.

**Table C.4 — External daylight factor  $D_{ext}$  as a function of the slope angle of the facade  $\gamma_f$  at a ground luminous reflectivity  $\rho_G$  of 0.2 (without obstruction)**

Slope angle $\gamma_f$ (°)	$D_{ext} = E_F / E_{ext}$ (%)
0	100
30	92
45	83
60	72
90	50

The utilization factor  $\eta_R$  is determined depending on the type of rooflight and the room index  $k$

$$k = \frac{a_R \times b_R}{h_R \times (b_R + a_R)} \quad (C22)$$

where:

$a_{R,j}$  room depth [m],

$b_{R,j}$  room width [m],

$h_R$  is the difference between the height of the room and the height of the working plane.

Generally, there is a distinction between rooflights as shown in Figure C.9 a,b,c and shed rooves as shown in Figure C.10. Continuous rooflights are treated as a special case of individual rooflights. When continuous rooflights have a ratio of  $a_s / b_s > 5$ , the utilization factor for  $a_s / b_s = 5$  should be used. Utilisation factors for different setups of rooflights and shed rooves are given in Table C.5 and Table C.6.

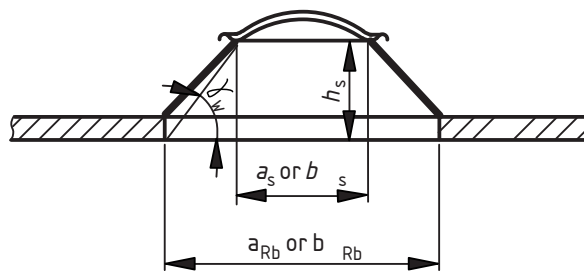



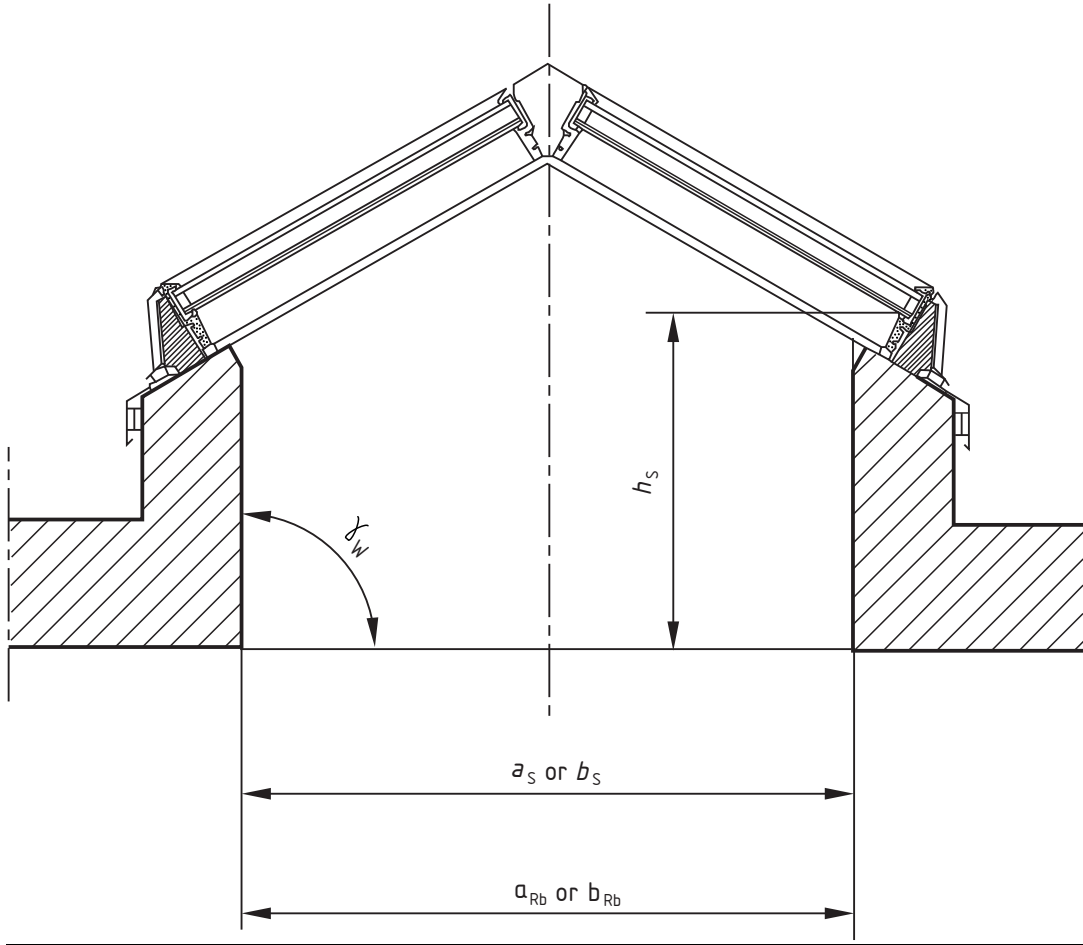

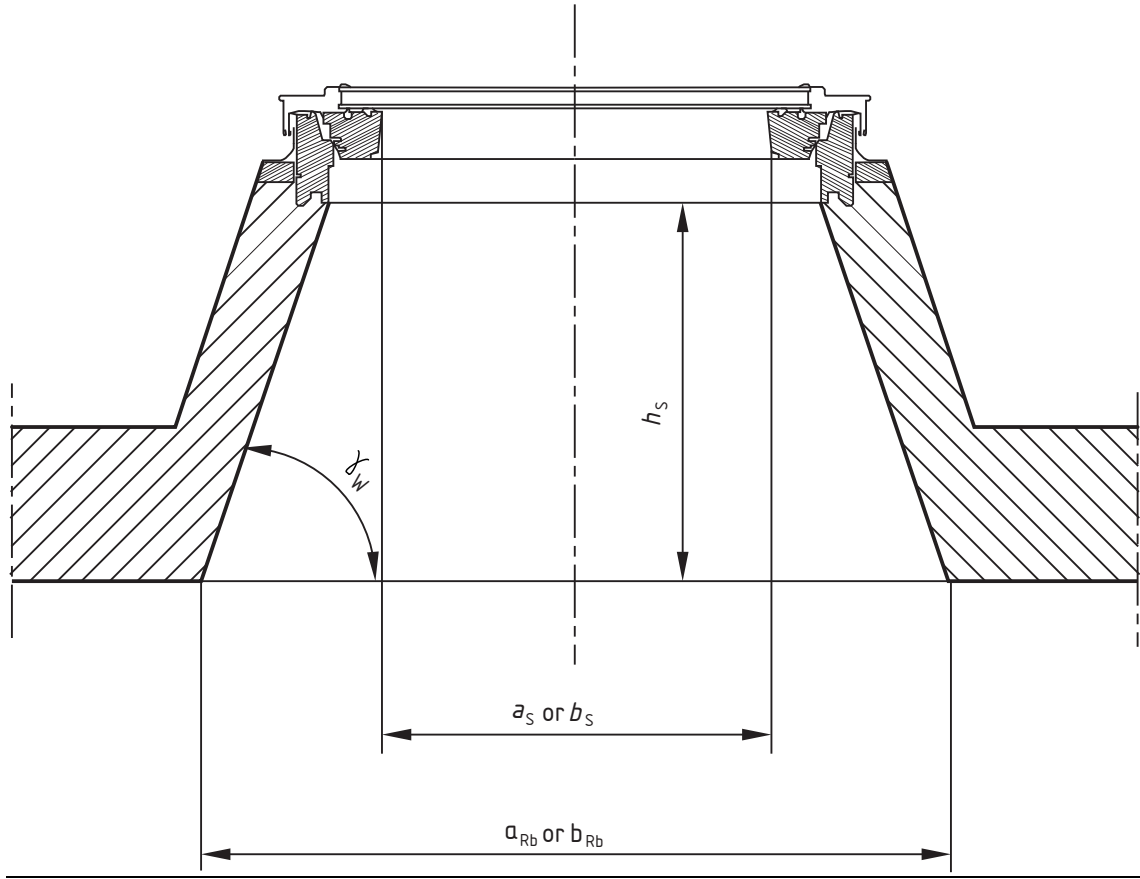

Figure C.9 — Quantities for describing the geometry of various roof lights

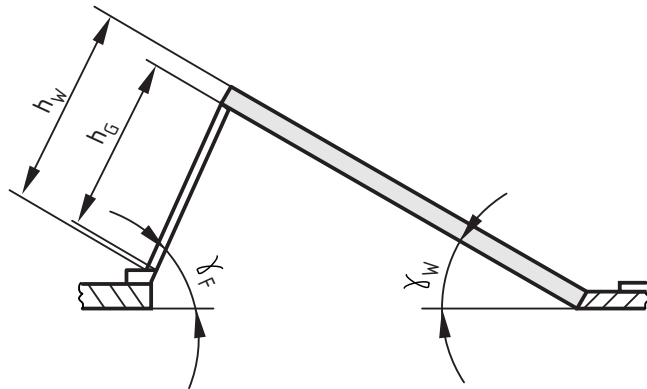

Figure C.10 — Quantities for describing the geometry of shed roofs

**Table C.5 — Utilization factor  $\eta_R$  in % for rooflights as a function of the room index  $k$  and the geometric parameters for the light-shaft of the rooflight**

$a_s/b_s$	1			2			5			1			2			5		
$h_s/b_s$	0,25			0,25			0,25			0,5			0,5			0,5		
$\gamma_w$	30	60	90	30	60	90		60	90	30	60	90	30	60	90	30	60	90
$k$																		
0,6	40	41	38	40	40	39	41	41	40	40	41	36	40	41	37	42	43	39
0,8	53	54	50	53	54	51	54	55	52	53	55	46	53	55	49	55	57	51
1,0	59	60	56	59	60	57	60	61	59	60	61	51	60	61	54	62	66	56
1,25	68	69	64	68	69	66	69	70	67	69	69	58	69	70	62	71	72	64
1,5	75	75	69	75	75	71	76	76	72	76	75	63	76	76	67	78	78	69
2,0	83	83	77	83	83	79	84	84	80	84	82	69	84	83	73	87	85	75
2,5	89	88	81	89	88	84	90	89	85	90	87	73	90	88	77	92	90	79
3,0	93	92	85	93	92	87	94	93	88	94	90	76	94	91	81	96	93	86
4,0	98	96	90	98	97	92	99	98	93	99	95	80	98	96	85	100	98	87
5,0	102	100	92	102	100	95	103	101	96	102	97	82	102	99	87	104	101	89

**Table C.6 — utilization factor  $\eta_R$  in % for shed rooves (saw tooth rooves) as a function of the room index  $k$  and the geometric parameters**

$h_G/h_W$	1												0,5													
	30				45	60				90				30				45	60				90			
$\gamma_F$	30	45	60	75	45	30	45	60	75	30	45	60	75	30	45	60	75	45	30	45	60	75	30	45	60	75
$\gamma_W$																										
$k$																										
0,6	39	39	41	40	37	34	35	36	35	29	30	31	31	38	39	39	40	36	33	34	35	36	29	29	30	30
0,8	51	52	53	50	49	44	45	46	44	37	39	39	38	50	51	52	51	48	43	44	45	44	37	37	38	38
1,0	57	58	58	55	55	50	52	51	49	44	45	45	44	56	57	57	56	53	49	50	51	50	43	44	44	44
1,25	66	66	65	62	62	58	59	58	55	51	51	51	49	65	65	65	64	61	57	58	58	56	50	51	50	50
1,5	72	72	71	67	68	64	64	63	60	56	56	56	54	71	71	71	69	67	62	63	63	61	55	56	55	55
2,0	80	79	77	73	75	72	71	69	66	64	63	62	60	79	79	78	76	75	71	71	70	68	62	63	62	61
2,5	85	84	81	77	80	77	76	73	70	69	68	66	64	84	84	83	80	80	76	76	75	72	68	68	67	65
3,0	88	88	84	80	83	81	79	76	72	72	71	69	67	88	88	86	83	84	80	80	78	75	72	71	70	68
4,0	94	92	88	84	87	85	83	80	76	77	75	73	70	93	93	91	87	88	85	84	82	79	77	76	75	72
5,0	97	95	91	87	90	89	86	82	78	80	78	75	73	97	96	93	90	92	89	88	85	81	80	79	77	75

The classification of the daylighting supply for rooflights is given in Table C.7.

**Table C.7 — Classification of the daylighting supply as a function of the daylight factor  $\bar{D}_j$**

Criterion	Classification of the daylighting supply
$7 \leq \bar{D}_j$ *	Strong
$4 \leq \bar{D}_j < 7$ %	Medium
$2 \leq \bar{D}_j < 4$ %	weak
$0 \leq \bar{D}_j < 2$ %	none

NOTE Values > 10 % should be avoided because of the danger of overheating.

If the daylight factor has been obtained by using other validated methods, it can be used instead of equation (C.1) to identify the classification of the daylighting supply (in accordance with Table C.6). Here, the daylight factor is the mean value on the working plane.

### C.3.2.2 Daylight supply factor

The daylight supply factor  $F_{D,S,n}$  may be determined by using tables similar to those shown in Table C.8. Variable sun protection systems are not considered. The data have been computed from hourly based weather datasets of the specified city locations. A simple interpolation as for vertical facades is not possible. For maintained illuminance values < 300 lux the values for 300 lux should be used for  $F_{DS,n}$ , and for maintained illuminances > 750 lux, the values for 750 lux should be used.

The data depending on the classification of the daylight supply, the maintained illuminance, different orientations and slope angles

The following daylight factors have been used in the calculations: low: 3 %, medium: 5,5 %, good:8,5 %.

**Table C 8— Daylight supply factor  $F_{DS,n}$  for rooflights in various cities**

**Table C 8 a —: Daylight supply factor in Athens (latitude 38°)**

Orientation	Classification of daylight supply Slope angles (°)	Maintained illuminance (lux)								
		$E_m=300$			$E_m=500$			$E_m=750$		
		weak	medium	strong	weak	medium	strong	weak	medium	strong
Horizontal	0	0.97	0.99	1.00	0.93	0.97	0.99	0.86	0.94	0.97
South	30	0.96	0.98	0.99	0.91	0.97	0.98	0.84	0.93	0.97
	45	0.94	0.98	0.99	0.88	0.96	0.98	0.80	0.93	0.96
	60	0.92	0.98	0.98	0.83	0.95	0.97	0.75	0.91	0.94
	90	0.81	0.96	0.97	0.68	0.92	0.93	0.57	0.85	0.86
East / West	30	0.94	0.98	0.99	0.88	0.95	0.98	0.79	0.91	0.96
	45	0.90	0.98	0.99	0.80	0.94	0.97	0.69	0.87	0.93
	60	0.84	0.97	0.98	0.70	0.91	0.95	0.59	0.82	0.88
	90	0.66	0.94	0.95	0.49	0.85	0.87	0.39	0.72	0.73
North	30	0.93	0.98	0.99	0.84	0.94	0.97	0.74	0.89	0.94
	45	0.87	0.97	0.99	0.75	0.92	0.96	0.62	0.84	0.90
	60	0.78	0.96	0.98	0.61	0.88	0.92	0.45	0.77	0.83
	90	0.50	0.92	0.93	0.27	0.79	0.81	0.18	0.60	0.62

**Table C 8 b —: Daylight supply factor in Lyon (latitude 46°)**

Orientation	Classification of of daylight supply  Slope angles (°)	Maintained illuminance (lux)								
		E <sub>m</sub> =300			E <sub>m</sub> =500			E <sub>m</sub> =750		
		weak	medium	strong	weak	medium	strong	weak	medium	strong
Horizontal	0	0.90	0.95	0.96	0.82	0.91	0.94	0.73	0.86	0.91
South	30	0.89	0.94	0.96	0.81	0.90	0.94	0.72	0.85	0.90
	45	0.88	0.94	0.96	0.79	0.89	0.93	0.70	0.83	0.89
	60	0.86	0.93	0.95	0.76	0.87	0.92	0.66	0.80	0.88
	90	0.80	0.89	0.93	0.68	0.82	0.89	0.57	0.73	0.82
East / West	30	0.89	0.94	0.96	0.80	0.90	0.94	0.69	0.84	0.90
	45	0.87	0.93	0.96	0.76	0.88	0.93	0.64	0.80	0.89
	60	0.84	0.92	0.95	0.70	0.85	0.92	0.57	0.76	0.86
	90	0.76	0.89	0.93	0.59	0.78	0.88	0.45	0.66	0.79
North	30	0.88	0.94	0.96	0.78	0.89	0.94	0.66	0.82	0.90
	45	0.85	0.93	0.96	0.72	0.87	0.93	0.58	0.78	0.88
	60	0.81	0.92	0.95	0.65	0.84	0.91	0.49	0.72	0.84
	90	0.71	0.88	0.93	0.49	0.75	0.86	0.33	0.58	0.76

**Table C 8 c —: Daylight supply factor in Bratislava (latitude 48°)**

Orientation	Classification of of daylight supply  Slope angles (°)	Maintained illuminance (lux)								
		E <sub>m</sub> =300			E <sub>m</sub> =500			E <sub>m</sub> =750		
		weak	medium	strong	weak	medium	strong	weak	medium	strong
Horizontal	0	0.87	0.92	0.94	0.79	0.88	0.92	0.70	0.82	0.88
South	30	0.86	0.92	0.94	0.78	0.87	0.91	0.70	0.81	0.88
	45	0.85	0.91	0.94	0.76	0.86	0.91	0.67	0.80	0.86
	60	0.83	0.90	0.93	0.74	0.84	0.89	0.64	0.77	0.84
	90	0.77	0.86	0.91	0.66	0.78	0.85	0.56	0.70	0.79
East / West	30	0.85	0.92	0.94	0.75	0.86	0.91	0.65	0.79	0.87
	45	0.82	0.91	0.94	0.71	0.84	0.90	0.59	0.76	0.85
	60	0.79	0.89	0.93	0.66	0.81	0.89	0.54	0.71	0.82
	90	0.71	0.85	0.90	0.55	0.73	0.83	0.42	0.61	0.74
North	30	0.84	0.92	0.94	0.73	0.85	0.91	0.61	0.77	0.86
	45	0.81	0.91	0.94	0.67	0.83	0.90	0.55	0.73	0.83
	60	0.77	0.89	0.93	0.60	0.79	0.88	0.44	0.67	0.80
	90	0.67	0.83	0.90	0.45	0.70	0.82	0.30	0.53	0.71



**Table C 8 d —: Daylight supply factor in Frankfurt (latitude 50°)**

Orientation	Classification of of daylight supply  Slope angles (°)	Maintained illuminance (lux)								
		E <sub>m</sub> =300			E <sub>m</sub> =500			E <sub>m</sub> =750		
		weak	medium	strong	weak	medium	strong	weak	medium	strong
Horizontal	0	0.88	0.95	0.97	0.78	0.89	0.94	0.66	0.82	0.9
South	30	0.85	0.94	0.96	0.73	0.87	0.93	0.62	0.79	0.88
	45	0.81	0.91	0.95	0.68	0.83	0.91	0.57	0.74	0.84
	60	0.75	0.88	0.93	0.61	0.77	0.86	0.51	0.67	0.78
	90	0.56	0.72	0.83	0.44	0.59	0.7	0.35	0.49	0.6
East / West	30	0.84	0.93	0.96	0.71	0.86	0.93	0.58	0.77	0.87
	45	0.78	0.91	0.95	0.63	0.81	0.9	0.5	0.7	0.82
	60	0.7	0.87	0.93	0.53	0.74	0.85	0.41	0.6	0.75
	90	0.46	0.67	0.81	0.33	0.5	0.65	0.24	0.38	0.51
North	30	0.82	0.93	0.95	0.69	0.85	0.92	0.55	0.75	0.86
	45	0.76	0.9	0.95	0.59	0.8	0.89	0.45	0.67	0.81
	60	0.66	0.85	0.92	0.45	0.71	0.83	0.31	0.54	0.72
	90	0.38	0.63	0.78	0.23	0.41	0.6	0.15	0.28	0.42

**Table C. 8 e —: Daylight supply factor in London (latitude 51 °)**

Orientation	Classification of of daylight supply  Slope angles (°)	Maintained illuminance (lux)								
		E <sub>m</sub> =300			E <sub>m</sub> =500			E <sub>m</sub> =750		
		weak	medium	strong	weak	medium	strong	weak	medium	strong
Horizontal	0	0.85	0.91	0.94	0.76	0.86	0.91	0.66	0.80	0.86
South	30	0.84	0.91	0.93	0.75	0.85	0.90	0.66	0.79	0.86
	45	0.83	0.90	0.93	0.73	0.84	0.89	0.64	0.77	0.84
	60	0.80	0.88	0.92	0.70	0.82	0.88	0.61	0.74	0.82
	90	0.74	0.84	0.89	0.62	0.76	0.83	0.52	0.67	0.76
East / West	30	0.83	0.90	0.93	0.72	0.84	0.90	0.62	0.77	0.85
	45	0.80	0.89	0.93	0.68	0.82	0.88	0.57	0.73	0.83
	60	0.77	0.88	0.92	0.63	0.79	0.87	0.51	0.69	0.80
	90	0.68	0.83	0.89	0.52	0.71	0.81	0.40	0.59	0.72
North	30	0.81	0.90	0.93	0.70	0.83	0.89	0.59	0.75	0.84
	45	0.78	0.89	0.93	0.65	0.80	0.88	0.52	0.70	0.81
	60	0.74	0.87	0.92	0.57	0.77	0.86	0.43	0.64	0.78
	90	0.64	0.81	0.88	0.45	0.67	0.80	0.31	0.52	0.68

**Table C. 8 f —: Stockholm (latitude 59,65°)**

Orientation	Classification of of daylight supply  Slope angles (°)	Maintained illuminance (lux)								
		E <sub>m</sub> =300			E <sub>m</sub> =500			E <sub>m</sub> =750		
		weak	medium	strong	weak	medium	strong	weak	medium	strong
Horizontal	0	0.75	0.82	0.86	0.66	0.76	0.81	0.56	0.69	0.76
South	30	0.75	0.82	0.86	0.67	0.76	0.81	0.58	0.70	0.77
	45	0.74	0.81	0.85	0.65	0.75	0.80	0.56	0.69	0.75
	60	0.72	0.80	0.84	0.63	0.73	0.79	0.54	0.67	0.74
	90	0.66	0.76	0.81	0.56	0.68	0.75	0.47	0.60	0.69
East / West	30	0.72	0.81	0.85	0.62	0.74	0.80	0.51	0.66	0.74
	45	0.70	0.80	0.84	0.58	0.71	0.79	0.47	0.63	0.72
	60	0.66	0.78	0.83	0.53	0.68	0.77	0.42	0.58	0.69
	90	0.58	0.72	0.79	0.43	0.60	0.71	0.32	0.49	0.61
North	30	0.71	0.80	0.85	0.60	0.72	0.79	0.49	0.64	0.73
	45	0.67	0.78	0.84	0.54	0.69	0.77	0.40	0.59	0.70
	60	0.63	0.76	0.82	0.45	0.66	0.75	0.32	0.53	0.66
	90	0.53	0.70	0.78	0.34	0.56	0.68	0.23	0.41	0.57

#### C.4 Daylight dependent artificial lighting control, $F_{D,C}$

$F_{D,C,n}$  describes the efficiency of how a control system or control strategy exploits the given saving potential, i.e. the daylight supply in the considered space, described by  $F_{D,S,n} \times F_{D,C}$  does not consider the power consumption of the control gear itself. Table C.9 provides the correction factor  $F_{D,C}$  of the daylight supply

Table C.9 —  $F_{D,C,n}$  as a function of daylight penetration

Control of artificial lighting system	$F_{D,C,n}$ as function of daylight penetration		
	weak	medium	strong
Manual	0,20	0,30	0,40
Automatic, daylight dependent	0,75	0,77	0,85

#### C.5 Monthly Method

Monthly values of the daylight dependency factor  $F_{D,n}$  can be obtained from the following equation:

$$F_{D,n} = 1 - (F_{D,S,n} \times F_{D,C,n} \times c_{D,S,n}) \quad (C23)$$

Where

$c_{D,S,i}$  is the monthly redistribution factor and given in Table C.10

**Table C.10 — Monthly redistribution factor  $c_{D,S,i}$  as function of daylight penetration**

Weather Station / Location		Jan	Feb	Mar	Apr	May	Jun	Jul	Aug	Sep	Oct	Nov	Dec
Watford, GB 52°N	weak	0.38	0.68	1.02	1.36	1.56	1.62	1.53	1.39	1.13	0.77	0.28	0.28
	medium	0.47	0.80	1.05	1.30	1.46	1.42	1.40	1.35	1.16	0.89	0.35	0.35
	strong	0.61	0.88	1.07	1.24	1.30	1.28	1.28	1.28	1.16	0.97	0.47	0.47
Frankfurt, D 50°N	weak	0,43	0,65	0,94	1,33	1,46	1,58	1,55	1,41	1,08	0,76	0,46	0,34
	medium	0,50	0,73	1,01	1,28	1,38	1,44	1,43	1,35	1,11	0,83	0,53	0,40
	strong	0,62	0,84	1,07	1,21	1,27	1,28	1,28	1,25	1,12	0,91	0,64	0,51
Athens, GR 38°N	weak	0.65	0.87	1.08	1.22	1.25	1.17	1.24	1.20	1.04	0.93	0.75	0.60
	medium	0.74	0.91	1.05	1.13	1.17	1.15	1.19	1.14	1.05	0.95	0.81	0.69
	strong	0.83	0.97	1.05	1.09	1.10	1.10	1.10	1.08	1.05	0.97	0.87	0.78
Bratislava, SK 48°N	weak	0.45	0.79	1.02	1.34	1.41	1.51	1.40	1.37	1.05	0.83	0.48	0.35
	medium	0.54	0.88	1.05	1.25	1.32	1.37	1.32	1.29	1.08	0.91	0.57	0.43
	strong	0.65	0.94	1.06	1.18	1.23	1.24	1.23	1.21	1.08	0.95	0.67	0.54
Lyon, F 46°N	weak	0.49	0.74	1.09	1.26	1.35	1.41	1.38	1.31	1.09	0.87	0.56	0.42
	medium	0.59	0.84	1.11	1.21	1.25	1.27	1.26	1.25	1.11	0.94	0.66	0.51
	strong	0.70	0.92	1.10	1.14	1.17	1.16	1.17	1.17	1.10	0.98	0.76	0.63
Gavle, S 61°N	weak	0.21	0.55	1.04	1.45	1.62	1.73	1.68	1.55	1.10	0.65	0.27	0.12
	medium	0.25	0.65	1.12	1.42	1.53	1.57	1.56	1.51	1.16	0.75	0.33	0.15
	strong	0.32	0.77	1.17	1.35	1.44	1.44	1.45	1.42	1.19	0.84	0.42	0.19

Summertime daylight can meet all of the daytime lighting requirements. Since  $F_{D,S,n} \times F_{D,C,n}$  - determined on a yearly basis - is weighed with monthly redistribution factors, for all months with  $F_{D,S,n} \times F_{D,C,n} \times c_{D,S,n} > 1$ , the difference ( $F_{D,S,n} \times F_{D,C,n} \times c_{D,S,n} - 1$ ) has to be summed up and has to be redistributed equally onto the monthly values  $F_{D,S,n} \times F_{D,C,n} \times c_{D,S,n}$  for those months which hold  $F_{D,S,n} \times F_{D,C,n} \times c_{D,S,n} < 1$ . Eventually this process has to be iterated.

## Annex D (informative)

### Determination of occupancy dependency factor $F_O$

#### D.1 Default value

Whatever type of control system is used, if  $F_O$  is taken as 1.0 in which case, no further analysis is needed. Otherwise, follow the rules below.

#### D.2 Detailed determination of $F_O$

When  $F_O = 1$

In the following cases,  $F_O$  should always be equal to 1

- If the lighting is switched on 'centrally', i.e. in more than one room at once (e.g. a single automatic system – for instance with timer or manual switch for an entire building, or for an entire floor, or for all corridors, etc.). This applies whatever the type of 'off-switch' (automatic or manual, central or per room, etc.).
- If the area illuminated by a group of luminaires that are (manually or automatically) switched together, is larger than 30 m<sup>2</sup>.

Exceptions are meeting rooms where this area limitation does not apply (see below).

When  $F_O \leq 1$

In the following cases,  $F_O$  should always be less than 1:

- a) in meeting rooms<sup>1</sup> (whatever the area covered by 1 switch and/or by 1 detector), as long as they are not switched on 'centrally', i.e. together with luminaires in other rooms.
- b) in other rooms, if the area illuminated by a luminaire or by a group of luminaires that are (manually or automatically) switched together, is not larger than 30 m<sup>2</sup>, and if the luminaires are all in the same room. In addition, in the case of systems with automatic presence and/or absence detection the area covered by the detector should closely correspond to the area illuminated by the luminaires that are controlled by that detector.

In both cases, also the conditions with respect to timing and dimming level outlined below should be fulfilled. (If these conditions are not satisfied,  $F_O = 1$ .)

In these instances,  $F_O$  should be determined as follows:

When  $0.0 \leq F_A < 0.2$

$$F_O = 1 - [(1 - F_{OC}) \times F_A / 0.2] \quad (D.1)$$

When  $0.2 \leq F_A \leq 0.9$

$$F_O = F_{OC} + 0.2 - F_A \quad (D.2)$$

When  $0.9 \leq F_A \leq 1.0$

$$F_O = [7 - (10 \times F_{OC})] \times (F_A - 1) \quad (D.3)$$

Where  $F_A$  is the proportion of the time that the space is unoccupied. Figure D.1, illustrates the impact of these equations.

In these expressions:

The default value of  $F_{OC}$  is fixed as a function of the lighting control system, as given in Table D.1.

The default value of  $F_A$  is determined at either building or room level as given in Table D.2.

**Table D.1 —  $F_{OC}$  values**

<b>Systems without automatic presence or absence detection</b>	$F_{OC}$
Manual On/Off Switch	1.00
Manual On/Off Switch + additional automatic sweeping extinction signal	0.95
<b>Systems with automatic presence and/or absence detection</b>	$F_{OC}$
Auto On / Dimmed	0.95
Auto On / Auto Off	0.90
Manual On / Dimmed	0.90
Manual On / Auto Off	0.80

For systems without automatic presence or absence detection the luminaire should be switched on and off with a manual switch in the room.

An automatic signal may also be included which automatically switches off the luminaire at least once a day, typically in the evening to avoid needless operation during the night.

For systems with automatic presence and/or absence detection the following situations are valid:

- a) 'Auto On / Dimmed': the control system switches the luminaire(s) automatically on whenever there is presence in the illuminated area, and automatically switches them to a state with reduced light output (of no more than 20 % of the normal 'on state') no later than 5 minutes after the last presence in the illuminated area. In addition, no later than 5 minutes after the last presence in the room as a whole is detected, the luminaire(s) are automatically and fully switched off.
- b) 'Auto On / Auto Off': the control system switches the luminaire(s) automatically on whenever there is presence in the illuminated area, and automatically switches them entirely off no later than 15 minutes after the last presence is detected in the illuminated area.
- c) 'Manual On / Dimmed': the luminaire(s) can only be switched on by means of a manual switch in (or very close to) the area illuminated by the luminaire(s), and, if not switched off manually, is/are automatically switched to a state with reduced light output (of no more than 20 % of the normal 'on state') by the automatic control system no later than 15 minutes after the last presence in the illuminated area. In addition, no later than 15 minutes after the last presence in the room as a whole is detected, the luminaire(s) are automatically and fully switched off.
- d) 'Manual On / Auto Off': the luminaire(s) can only be switched on by means of a manual switch in (or very close to) the area illuminated by the luminaire(s), and, if not switched off manually, is automatically and entirely switched off by the automatic control system no later than 15 minutes after the last presence is detected in the illuminated area.

**Table D.2 — Sample  $F_A$  values**

Overall building calculation		Room by room calculation		
Building type	$F_A$	Building type	Room type	$F_A$
<b>Offices</b>	0.20	<b>Offices</b>	Cellular office 1 person.	0,4
			Cellular office 2-6 persons.	0,3
			Open plan office >6persons sensing/30m <sup>2</sup>	0
			Open plan office >6persons sensing/10m <sup>2</sup>	0,2
			Corridor (dimmed)	0,4
			Entrance hall	0
			Showroom/Expo	0,6
			Bathroom	0,9
			Rest room	0,5
			Storage room/Cloakroom	0,9
			Technical plant room	0,98
			Copying/Server room	0,5
			Conference room	0,5
			Archives	0,98
<b>Educational buildings</b>	0,2	<b>Educational buildings</b>	Classroom	0,25
			Room for group activities	0,3
			Corridor (dimmed)	0,6
			Junior common room	0,5
			Lecture hall	0,4
			Staff room	0,4
			Gymnasium/Sports hall	0,3
			Dining hall	0,2
			Teachers' staff common room	0,4
			Copying/storage room	0,4
			Kitchen	0,2
			Library	0,4
<b>Hospitals</b>	0	<b>Hospitals</b>	Wards/Bedroom	0
			Examination/Treatment	0,4
			Pre-Operation	0,4
			Recovery ward	0
			Operating theatre	0
			Corridors	0
			Culvert/conduct/(dimmed)	0,7
			Waiting area	0
			Entrance hall	0
			Day room	0,2
			Laboratory	0,2
<b>Manufacturing factory</b>	0	<b>Manufacturing factory</b>	Assembly hall	0
			Smaller assembly room	0,2
			Storage rack area	0,4
			Open storage area	0,2
			Painting room	0,2



Overall building calculation		Room by room calculation		
Building type	$F_A$	Building type	Room type	$F_A$
Hotels and restaurants	0	Hotels and restaurants	Entrance hall/Lobby	0
			Corridor (dimmed)	0,4
			Hotel room	0,6
			Dining hall/cafeteria	0
			Kitchen	0
			Conference room	0,4
			Kitchen/storage	0,5
Wholesale and retail service	0	Wholesale and retail service	Sales area	0
			Store room	0,2
			Store room, cold stores	0,6
		Other areas	Waiting areas	0
			Stairs (dimmed)	0,2
			Theatrical stage and auditorium	0
			Congress hall/Exhibition hall	0,5
			museum/ Exhibition hall	0
			Library/Reading area	0
			Library /Archive	0,9
			Sports hall	0,3
			Car parks office - Private	0,95
			Car parks - Public	0,8

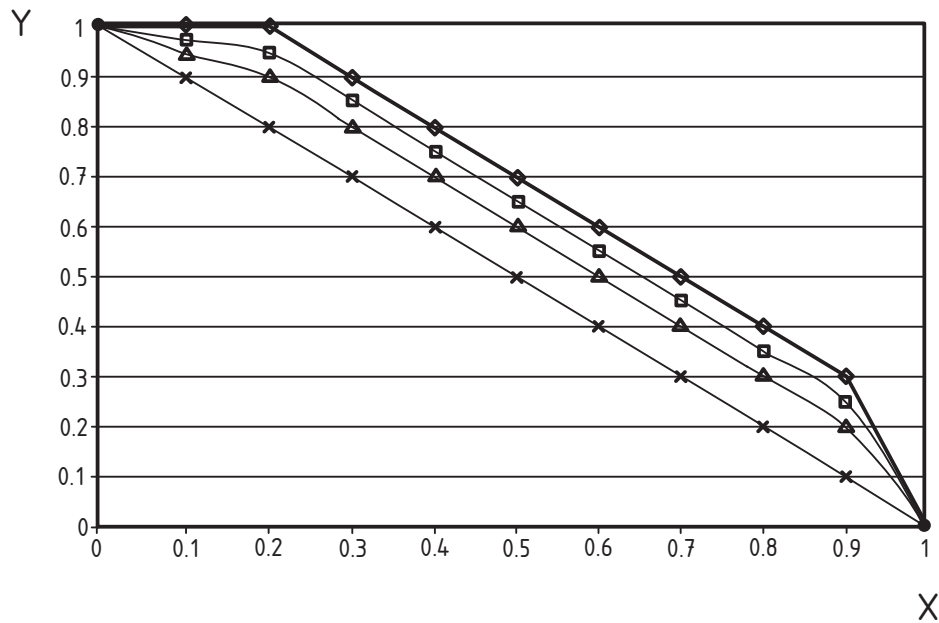

**Key**

- ◆ 1
- 2
- ▲ 3
- × 4

1. Manual On/Off switch
2. Manual On/Off Switch + additional automatic sweeping extinction signal, and Auto on/Dimmed
3. Auto on/Auto off and Manual on/Dimmed
4. Manual on/Auto Off

**Figure D.1 —  $F_O$  as a function of  $F_A$  for the different control systems**

**Table D.3 —  $F_O$  values as a function of  $F_A$  for the different control systems**

$F_A$	0.0	0.1	0.2	0.3	0.4	0.5	0.6	0.7	0.8	0.9	1.0
Manual On/Off switch	1.000	1.000	1.000	0.900	0.800	0.700	0.600	0.500	0.400	0.300	0.000
Manual On/Off Switch + additional automatic sweeping extinction signal	1.000	0.975	0.950	0.850	0.750	0.550	0.650	0.450	0.350	0.250	0.000
Auto on/Dimmed	1.000	0.975	0.950	0.850	0.750	0.550	0.650	0.450	0.350	0.250	0.000
Auto on/Auto off	1.000	0.950	0.900	0.800	0.700	0.600	0.500	0.400	0.300	0.200	0.000
Manual on/Dimmed	1.000	0.950	0.900	0.800	0.700	0.600	0.500	0.400	0.300	0.200	0.000
Manual on/Auto Off	1.000	0.900	0.800	0.700	0.600	0.500	0.400	0.300	0.200	0.100	0.000

NOTE 1 These include e.g. classical meeting rooms in office buildings and hotels, classrooms, cinemas, pubs.

NOTE 2 For e.g. programming purposes, this can be rewritten as a single expression:

$$F_O = \min\{1 - [(1 - F_{OC}) \times F_A / 0.2]; (F_{OC} + 0.2 - F_A); [7 - (10 \times F_{OC})] \times (F_A - 1)\} \quad (D4)$$

NOTE 3 The value of  $F_O$  can range from 0 to 1. The absence factor corresponds to the fraction of the reference operating time ( $t_D + t_N$ ) that a building or room is not in use. (Sleeping hours can usually be considered equivalent to absence.) When the building or the room would be permanently occupied during the reference time,  $F_A$  would be 0.0. As a limit value, if a building or room would nearly never ever be entered into,  $F_A$  would tend towards 1.0.

NOTE 4 This table gives some values for  $F_{OC}$  as a function of the lighting control system. For other types of control systems, other values may be determined; this table is open-ended. The "off-time" of the luminaires with respect to the reference operating time ( $t_D + t_N$ ) can never be more than  $F_A$ . (Remember "off-state" due to daylight is not considered here but included in  $F_D$ .) Therefore  $F_O$  can never be more than  $1 - F_A$ . This implies that  $F_{OC}$  should be at least 0.80.

### D.3 Motivation for the choice of $F_O$ functions

The aim of the use of the  $F_O$  factor is to give a (rudimentary) appreciation of the energy efficiency of the lighting control system.  $F_O$  depends on 2 factors:

- the type of control system;
- the degree of absence of the room or the building.

**The simple model (i.e. the shape of the curves) is purely empirical.**

$F_O$  decreases as the room/building is less and less occupied, i.e. as  $F_A$  becomes larger.

For values of  $F_A$  below 0.2, the slope of the curves is different to make them all converge to  $F_O = 1.0$  for  $F_A = 0.0$ .

For values of  $F_A$  between 0.2 and 0.9, the slope of the curves is identical, i.e. all curves are parallel. In this range the difference in  $F_O$  among control systems is thus independent of the absence level.

For values of  $F_A$  greater than 0.2, the slope of the curves is different to make them all converge to  $F_O = 0.0$  when  $F_A = 1.0$ .

**Also the values of  $F_{OC}$  are purely empirical.**

Following qualitative (based on the real system monitoring) considerations have been integrated:

- a) Complementing manual on/off switches with an additional 'automatic sweeping extinction signal' prevents luminaires remaining alight after all users have left the building (typically at night). So these systems get a better appreciation than purely manual on/off systems.
- b) Automatic systems that remain alight in a dimmed state when there is no more presence in the illuminated area, consume more than those that switch off completely, hence a higher  $F_{OC}$  and  $F_O$  factor. In large rooms (e.g. landscape offices) building users often object to the fact that the light completely switches off in other, unoccupied parts of the room. There is thus a real demand and application for these types of systems.
- c) Systems that automatically switch on, often do so when it is not needed. For instance, when a person briefly enters a room to pick up a forgotten item, to distribute mail, etc., artificial lighting is usually unnecessary, but the system will switch on anyway. Many presence sensors also detect through open doors motion in corridors of passers-by, every time needlessly switching on the lights in the room, also after standard occupation hours (e.g. regular passage of a cleaning crew through a hall, a few late workers who go and see each other, go to the printer, copier, coffee machine or toilets, etc.). Therefore  $F_{OC}$  is more favourable (smaller) for systems that only switch

on when the user commands so through a manual switch. An additional advantage of systems that are switched on manually is that they do not need to detect entry into the room, but only exit. The detection system can therefore be switched off together with the luminaires. In many instances the 'off-hours' are a substantial fraction of the year. This configuration therefore constitutes a major means to reduce parasitic power consumption, apart from reducing the installed parasitic power itself.

NOTE Daylight influence on switching behaviour, during room occupation time, is taken into account in the factor  $F_D$ .

## **Annex E** (informative)

### **Determination of the constant illuminance factor $F_c$**

#### **E.1 Introduction**

All lighting installations, from the instant they are installed, start to decay and reduce their output. In the design of the lighting scheme the decay rate is estimated and applied in the calculations known as the Maintenance Factor ( $MF$ ). The Maintenance Factor ( $MF$ ) is the ratio between Maintained Illuminance and Initial Illuminance.

As the task illuminance is specified in terms of “maintained illuminance” to assure conformity the scheme should provide higher initial illuminance by a factor  $1/MF$ . The  $MF$  is made up of multiples of factors such as  $LLMF$ ,  $LMF$ , and  $RSMF$ . Full details of the derivation of  $MF$  can be found in CIE 97.

In installations where a dimmable lighting system is provided, it is possible to automatically control and reduce the initial luminaire output to just provide the required maintained illuminance. Such schemes are known as “controlled constant illuminance” systems. These schemes will also benefit from reduced energy use, power demand. As the light output decays with time, the controls raise input power to the luminaire to compensate. When the power demand equals the installed power the lighting system requires maintenance such as clean luminaires, change lamps, clean room surfaces. Figure E.1 illustrates the impact of variable power supply to compensate for the declining maintenance factor to maintain the constant maintained illuminance in one maintenance cycle.

#### **E.2 Power for constant illuminance factor**

The power for constant illuminance factor is the ratio of the actual input power at a given time to the initial installed input power to the luminaire.

#### **E.3 Constant illuminance factor ( $F_c$ )**

The constant illuminance factor is the ratio of the average input power over a given time to the initial installed input power to the luminaire. Normally the time is taken to be the period of one complete maintenance cycle.

Therefore:

$$F_c = (1 + MF)/2 \tag{E1}$$

Where  $MF$  is the maintenance factor for the scheme.

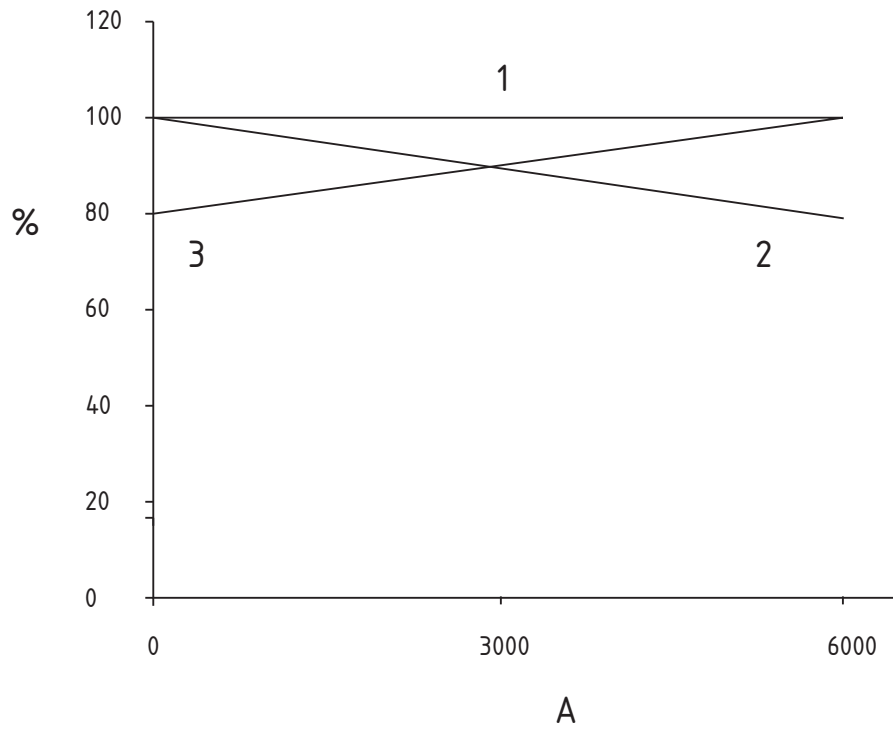

**Key:**

- 1 = Illuminance
- 2 = Maintenance factor
- 3 = Power
- A = Time in use (hours)

**Figure E.1 — Constant illuminance diagram**

**Annex F**  
**(informative)**  
**Benchmark values and lighting design criteria**  
**Table F.1 — Bench mark default value**

	Qual. class	Parasitic Emergency kWh/(m <sup>2</sup> /year)	Parasitic Control kWh/(m <sup>2</sup> /year)	PN W/m <sup>2</sup>	t <sub>b</sub> h	t <sub>N</sub> h	F <sub>c</sub>		F <sub>o</sub>		F <sub>D</sub>		no	cte	cte illiminance	
							no cte illiminance	cte illiminance	Manu	Auto	Manu	Auto	LENI	LENI	LENI	LENI
Office	*	1	5	15	2250	250	1	0.9	1	0.9	1	0.9	42.1	35.3	38.3	32.2
	**	1	5	20	2250	250	1	0.9	1	0.9	1	0.9	54.6	45.5	49.6	41.4
	***	1	5	25	2250	250	1	0.9	1	0.9	1	0.9	67.1	55.8	60.8	50.6
Education	*	1	5	15	1800	200	1	0.9	1	0.9	1	0.8	34.9	27.0	31.9	24.8
	**	1	5	20	1800	200	1	0.9	1	0.9	1	0.8	44.9	34.4	40.9	31.4
	***	1	5	25	1800	200	1	0.9	1	0.9	1	0.8	54.9	41.8	49.9	38.1
Hospital	*	1	5	15	3000	2000	1	0.9	0.9	0.8	1	0.8	70.6	55.9	63.9	50.7
	**	1	5	25	3000	2000	1	0.9	0.9	0.8	1	0.8	115.6	91.1	104.4	82.3
	***	1	5	35	3000	2000	1	0.9	0.9	0.8	1	0.8	160.6	126.3	144.9	114.0
Hotel	*	1	5	10	3000	2000	1	0.9	0.7	0.7	1	1	38.1	38.1	34.6	34.6
	**	1	5	20	3000	2000	1	0.9	0.7	0.7	1	1	72.1	72.1	65.1	65.1
	***	1	5	30	3000	2000	1	0.9	0.7	0.7	1	1	108.1	108.1	97.6	97.6
Restaurant	*	1	5	10	1250	1250	1	0.9	1	1	1	-	29.6	-	27.1	-
	**	1	5	25	1250	1250	1	0.9	1	1	1	-	67.1	-	60.8	-
	***	1	5	35	1250	1250	1	0.9	1	1	1	-	92.1	-	83.3	-
Sport places	*	1	5	10	2000	2000	1	0.9	1	1	1	0.9	43.7	41.7	39.7	37.9
	**	1	5	20	2000	2000	1	0.9	1	1	1	0.9	83.7	79.7	75.7	72.1
	***	1	5	30	2000	2000	1	0.9	1	1	1	0.9	123.7	117.7	111.7	106.3
Retail	*	1	5	15	3000	2000	1	0.9	1	1	1	-	78.1	-	70.6	-
	**	1	5	25	3000	2000	1	0.9	1	1	1	-	128.1	-	115.6	-
	***	1	5	35	3000	2000	1	0.9	1	1	1	-	178.1	-	160.6	-
Manufacture	*	1	5	10	2500	1500	1	0.9	1	1	1	0.9	43.7	41.2	39.7	37.5
	**	1	5	20	2500	1500	1	0.9	1	1	1	0.9	83.7	78.7	75.7	71.2
	***	1	5	30	2500	1500	1	0.9	1	1	1	0.9	123.7	116.2	111.7	1.5.0

$$\text{Where LENI} = \{F_c \times P_N/1000 \times [(t_D \times F_D \times F_O) + (t_N \times F_O)]\} + 1 + \{5/t_y \times [t_y - (t_D + t_N)]\} \text{ [kWh/(m}^2 \times \text{year)]} \quad (\text{F1})$$

PN is the installed lighting power density load in the building in W/m<sup>2</sup>

cte is constant illuminance control system

Manu is manual control lighting system

Auto is automatic control lighting system

Lighting should be designed and installed by following good lighting practices. The lighting design criteria are given in the EN 12464-1 "Lighting of workplaces – Indoor work places" and EN 12193 Sports Lighting. Each of the criteria has to be considered. The lighting design should fulfil the basic lighting requirements. For an improved lighting design, to achieve better comfort conditions, well-being of and acceptance by the user the following three lighting design classes should be considered:

Quality class (Qual. Class)

- \* basic fulfilment of requirements
- \*\* good fulfilment of requirements
- \*\*\* comprehensive fulfilment of requirements. The lighting design criteria are listed in Table F2.



Table F.2 — Lighting design criteria class

	Lighting design criteria class		
	*	**	***
Maintained illuminance on horizontal visual tasks ( $E_{M \text{ horizontal}}$ )	☑	☑	☑
Appropriate control of discomfort glare (UGR)	☑	☑	☑
Avoidance of flicker and stroboscopic effects	✓	✓	✓
Appropriate control of veiling reflections and reflected glare		✓	✓
Improved colour rendering		☑	☑
Avoidance of harsh shadows or too diffuse light in order to provide good modelling		✓	✓
Proper luminance distribution in the room ( $E_{\text{vertical}}$ )		✓	✓
Special attention of visual communication in lighting faces ( $E_{\text{cylindrical}}$ )			✓
Special attention to health issues (Note)			✓
<p>☑: has to comply with required values from Tables 5.3 in EN 12464-1</p> <p>✓: has to conform to verbally described requirements from EN 12464-1</p> <p>NOTE health issues may even require much higher illuminances and therefore higher <math>W/m^2</math></p> <p>The maximum power density load (<math>PM</math>) connected to the lighting design class is given in the benchmark Table F.1.</p>			

## Annex G (informative)

### Default values

**G.1 The default values for annual operating hours relating to building type are given in Table G.1.**

**Table G.1 — Default annual operating hours relating to building type**

Building types	Default annual operating hours		
	$t_D$	$t_N$	$t_O$
Offices	2 250	250	2 500
Education buildings	1 800	200	2 000
Hospitals	3 000	2 000	5 000
Hotels	3 000	2 000	5 000
Restaurants	1 250	1 250	2 500
Sports facilities	2 000	2 000	4 000
Wholesale and retail services	3 000	2 000	5 000
Manufacturing factories	2 500	1 500	4 000
NOTE National values may be substituted where necessary.			

The default values for impact of daylight for buildings with controls is given in Table G.2.

**Table G.2 — Impact of daylight for buildings with controls**

Daylight impact		
Building type	Control type	$F_D$
Office, sports facilities, manufacturing	Manual	1.0
	Photo cell dimming – with daylight sensing	0.9
Restaurant, wholesale and retail	Manual	1.0
Education buildings, Hospitals	Manual	1.0
	Photo cell dimming – with daylight sensing	0.8
NOTE 1 Assumes at least 60 % of the lighting load is under the given control.		
NOTE 2 National values may be substituted where necessary.		

The default values of occupancy for buildings with controls is given in Table G.3.

**Table G.3 — Impact of occupancy for buildings with controls**

Occupancy impact		
Building type	Control type	$F_O$
Office	Manual	1.0
Education	Automatic $\geq$ 60 % of the connected load	0.9
Retail, Manufacture, Sports and Restaurant	Manual	1.0
Hotel	Manual	0.7
Hospital	Manual (some automatic control)	0.8
NOTE 1 Automatic controls with presence sensing should be allocated at least 1 per room and in large areas and at least one per 30 m <sup>2</sup> .		
NOTE 2 National values may be substituted where necessary.		

## **Annex H** (informative)

### **Other considerations**

#### **H.1 Individual dimming**

Additional energy savings can be made when using a localised lighting system with individual dimming in the work place.

Individual dimming can also improve lighting comfort in work places when lighting can be adjusted to individual needs and to a preferred luminance distribution. Energy savings of between 0 and 40 % may be achieved.

#### **H.2 Algorithmic lighting**

The lighting profession has recognized the importance of designing lighting installations to take non visual biological effects into account and this is related to the regulation of certain hormones in the human body. It is to be expected that a future revision of the standard EN 12464-1 will incorporate the aspects of the non-visual biological effects of artificial lighting.

To optimise the biological effects through lighting, higher lighting levels than required for pure visual effects are necessary for part of the day (especially in the morning and early afternoon). These higher lighting levels can be limited considerably if cool white light is used (colour temperature up to some 6000K). At moments when less biological effective lighting is required the lighting can be of warmer colour and reduced gradually to the minimum level required for pure vision only. The automatic changing of lighting level, direction and colour temperature in the course of the day is called "algorithmic lighting". To change the colour temperature, these installations use different coloured light sources or light sources with different colour temperature in one luminaire. The light sources are also dimmed in proportions to obtain different light levels and colour temperatures.

Typically, for an algorithmic lighting installation, the total installed lighting load will be greater than that of a non-algorithmic lighting system. However, this lighting is not usually used at maximum demand for long periods. The actual power used is likely to be in the range of 30 % to 70 % of the installed load dependant on the scheme.

#### **H.3 Light pipes**

Additional energy savings may be obtained when utilising daylight pipes (or tubular daylight guidance systems). Light pipes allow daylight to be directed through most attic obstructions as well as they can provide daylight through one or more stories - to dark areas of a building, where the light from conventional facade or roof light systems cannot reach.

Light pipes are basically a metal or plastic tube that delivers daylight from the roof into the building. The typical light pipe includes

- 1) a roof-mounted plastic dome or a glazed window frame which captures sunlight;
- 2) a reflective tube that stretches from the dome to the interior ceiling and
- 3) a ceiling-mounted diffuser that spreads the light to the room.

There are a number of systems available: Either with flexible reflective tubes or with rigid reflective tubes.

## H.4 Lighting installations with Scene Setting

Sometimes the activities in a room vary in the course of the day and the lighting needs to be adapted to the different activities. This may for example be the case in conference and meeting rooms where the activities may vary from presenting slides on a screen, discussions between participants to reading and writing and working with individual PCs. In an office the activities may for example vary from reading and writing, working with PC's, using CAD workstations and discussions with colleagues or visitors. If for each of these different activities, specific lighting can be switched on (often remotely controlled), we speak of "scene setting". Typically for scene setting, different settings are never used at the same moment, thus the total installed power is never used. For calculating the actual power used in the course of a day or year the average use of each different setting corresponding to each specific activity has to be predicted.

$$W_{\text{actual}} = \sum \left( \frac{t_{\text{setting1}}}{t_s} \times W_{\text{setting1}} \right) + \left( \frac{t_{\text{setting2}}}{t_s} \times W_{\text{setting2}} \right) \quad (\text{H.1})$$

$$t_s = t_{\text{Setting 1}} + t_{\text{Setting 2}} + \dots \dots \dots (\text{h}) \quad (\text{H.2})$$

where  $t_s$  is the total operating time of the scene setting

Where  $t_{\text{setting}}$  is the envisaged setting is in use

Where  $W_{\text{setting}}$  is the total power of all luminaires forming part of the envisaged setting.

## H.5 Daylight Guidance

### H.5.1 Vertical facades

Deeper areas of laterally lit spaces often suffer from insufficient daylight supply, enlarging the need for costly artificial lighting use and eventually increasing cooling loads by additional internal heat gains through artificial lighting. In addition, conventional shading systems often reduce the incoming light to the point that artificial lighting is required, although outside light supply is plentiful. Here daylight guiding systems represent an important design option to obtain additional energy savings. Diverse technical solutions are available nowadays.

For central European conditions, one robust strategy uses the upper quarter or third of the transparent facade elements for redirecting direct daylight via the ceiling into deeper areas of the considered space – while at the same time avoiding glare problems in the task areas. This solution provides, in most cases, the benefit of introducing enough additional daylight into the space while still limiting the penetration of additional amounts of solar radiation (overheating risk in summertime). Diverse venetian blind systems, of which the upper part can separately be tilted and lamella systems for indoor purposes with high reflective coatings are available, as are also specially designed light redirection glasses. Aside guiding direct light into the space, other systems work by rejecting direct sunlight from the facade while still allowing sufficient amounts of diffuse daylight to enter the space. Lamellas can be operated in a so called “cut-off mode”, i.e. just merely blocking the direct sunlight incidence into the space. Systems with prismatic elements employ light refraction principles. For many of the systems, additional controls for positioning the optically effective components (e.g. lamellas or prisms) have to be considered. Design of such systems also has to take into account that they are reliant on orientation and façade obstruction. Static light shelves are effective alternative solutions in some European climates. Systems working on concentration and guidance of diffuse light have been photometrically developed but have not yet been employed on a large scale.

### H.5.2 Rooflights

For rooflight situations daylight guidance has shown to be of less importance, since these systems generally illuminate spaces more evenly. Special designed micropanels can nevertheless provide effective sun shading functionality while letting large portions of diffuse skylight to enter the space.

Examples of rooflight solutions are illustrated in Figure H.1.

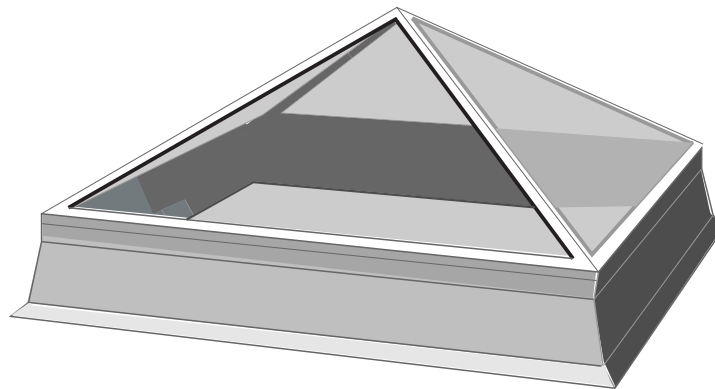

H.1 a) Glass pyramid

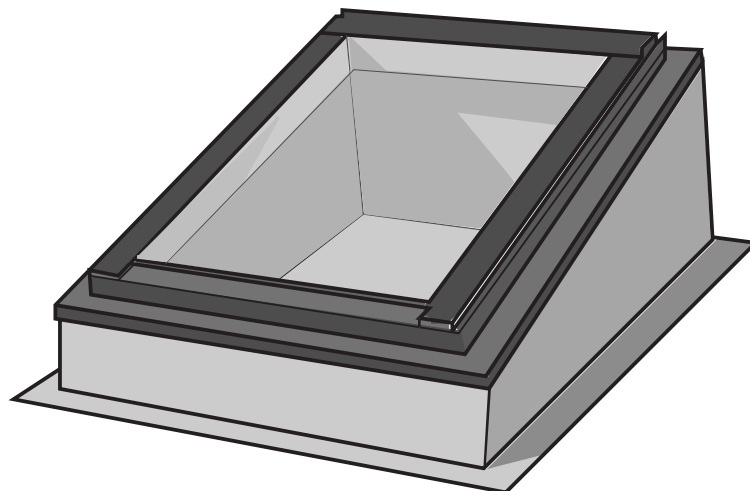

H.1 b) Glass roof window

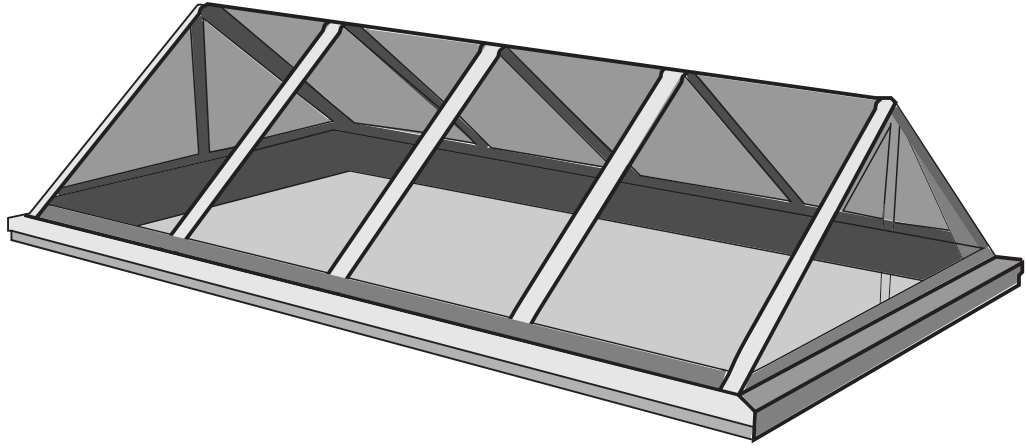

H.1 c) Glass ridge

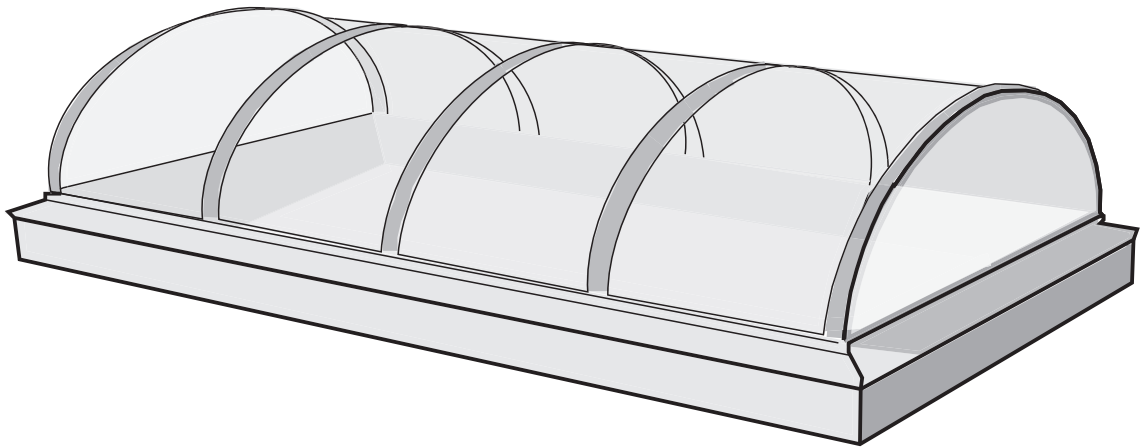

H.1 d) Polycarbonate ridge

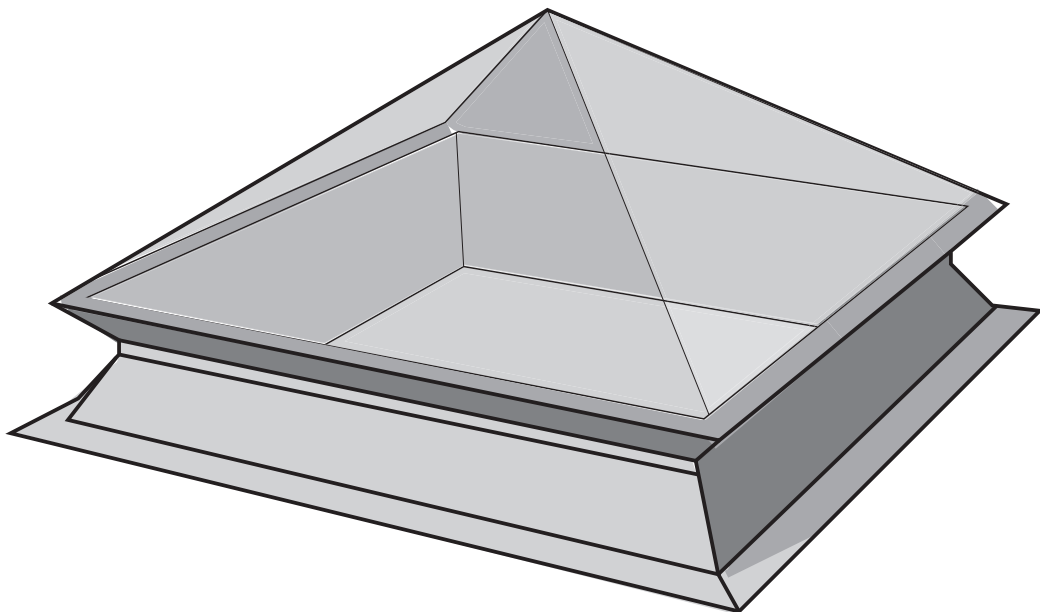

H.1 e) Polycarbonate pyramid

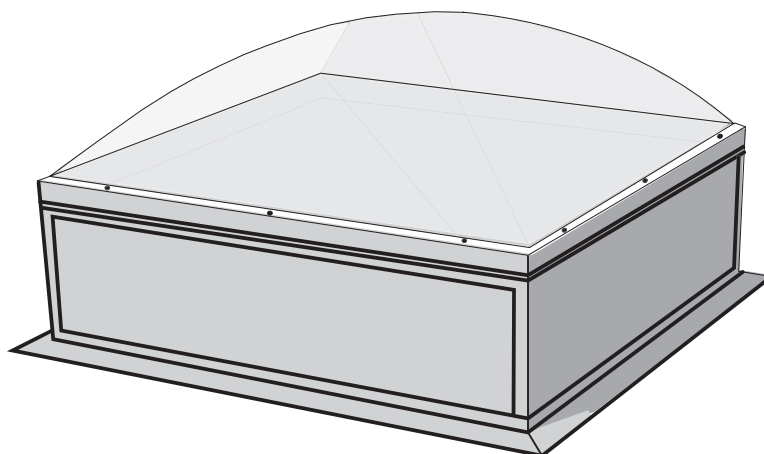

H.1 f) Polycarbonate dome

**Figure H.1 — Examples of rooflights**



## Annex I (informative)

### Symbols and their definitions

$A$	Total useful floor area of the building [ $m^2$ ]
$a_D$	Depth of daylight zone [m]
$A_D$	Total area of horizontal work plane benefiting from daylight [ $m^2$ ]
$A_C$	Area of the façade opening (carcass opening) of the considered space [ $m^2$ ]
$A_{Fs}$	Light input area of rooflight [ $m^2$ ]
$A_{D,j}$	Maximum room depth [m]
$A_{RG}$	Surface area of considered space [ $m^2$ ]
$A_{Rb}$	Area of the roof light openings (area of carcass opening) [m]
$a_{D,max}$	Maximum depth of daylight area [m]
$b_D$	Width of daylight area [m]
$b_{R,j}$	Room width [m]
$c_{D,S,i}$	Redistribution factor for the specific month
$D$	Daylight factor for zone [%]
$D_C$	Daylight factor for carcass façade opening [%]
$D_{ext}$	External daylight factor [%]
$\overline{D}_j$	Classification of the day lighting supply as a function of the daylight factor
$E_m$	Average maintained illuminance [lux]
$E_F$	Illuminance on the outer surface of the skylight for overcast sky conditions [lux]
$E_{ext}$	Horizontal outdoor illuminance at overcast sky conditions [lux]
$F_A$	Absence factor
$F_c$	Constant illuminance factor
$F_{D,j}$	Surfaces within the space of calculation not receiving any daylight
$F_D$	Daylight dependency factor
$F_{D,n}$	Daylight dependency factor in room or zone
$F_{D,C,n}$	Daylight dependent electric lighting control factor in zone n
$F_{DS}$	Daylight supply factor

$F_{D,S,n}$	Daylight supply factor in zone n
$F_{S,n}$	Daylight supply factor for roof lights
$F_O$	Occupancy dependency factor
$F_{OC}$	Occupancy dependent lighting control system factor
$F_{o,n}$	Occupancy dependency factor in zone n
$h_{At}$	Height of atrium or courtyard [m]
$h_{Li}$	Height of lintel above floor [m]
$h_{Ta}$	Height of task area (work plane) above floor [m]
$h_R$	Height of clear room (for calculation with roof light) [m]
$l_{At}$	Length of atrium or courtyard [m]
$l_{De}$	Depth index
$l_o$	Obstruction index, correction factor for obstruction
$l_{o,CA}$	Correction factor, courtyard and atria
$l_{o,OB}$	Correction factor linear, opposite obstruction
$l_{o,GDF}$	Correction factor for glazed double facades
$l_{o,OV}$	Correction factor overhang
$l_{o,VF}$	Correction factor for vertical fins
$l_T$	Transparency index
$k$	Room index
$k_1$	Factor accounting for frame of fenestration system
$k_2$	Factor accounting for dirt on glazing
$k_3$	Factor accounting for not normal light incidence on façade
$k_{AT,1}$	Factor accounting for frames of atrium roof
$k_{AT,2}$	Factor accounting for dirt on atrium roof
$k_{AT,3}$	Factor accounting for not normal light incidence on façade
$k_{GDF,1}$	Factor accounting for frames of glazed double façade
$k_{GDF,2}$	Factor accounting for dirt of glazed double facade
$k_{GDF,3}$	Factor accounting for not normal light incidence on façade (0,85, in general sufficient)
$k_{OBI,1}$	Factor for considering framing (rooflight)
$k_{OBI,2}$	Factor for considering dirt (rooflight)

$k_{OBI,3}$	Factor considering non-perpendicular light incidence (usually 0,85) (rooflight)
$LENI$	Lighting Energy Numeric Indicator [kWh/m <sup>2</sup> .year]
$LLMF$	Lamp Lumens Maintenance Factor
$LSF$	Lamp Survival Factor
$LMF$	Luminaire Maintenance Factor
$MF$	Maintenance Factor
$RSMF$	Room Surface Maintenance Factor
$\eta_R$	Utilization factor for rooflights [%]
$n$	Number of rooms or zones in the building
$P_i$	Luminaire input power [W]
$P_n$	Total installed lighting power in the room or zone [W]
$PN$	The required installed power density for electric lighting in the building [W/m <sup>2</sup> ]
$P_p$	Luminaire parasitic power [W]
$P_{ci}$	Parasitic power for the controls only during standby (the time with the lamps off) [W]
$P_{ei}$	Parasitic power for the emergency lighting luminaire charging only [W]
$P_{pi}$	Luminaire parasitic input power [W]
$P_{pc}$	Total installed parasitic power of the controls in the room or zone [W]
$P_{pn}$	Total installed lighting power in the room or zone [W]
$P_{em}$	Total installed input charging power of the emergency lighting luminaires in the room or zone [W]
$\tau$	Direct hemispherical transmission factor of fenestration
$\tau_{At}$	Transmission factor of atrium glazing
$\tau_{GDF}$	Transmission factor of glazed double facade
$\tau_{D65}$	Transmission factor of scattering roof glazing
$t$	Operating time [h]
$t_D$	Daylight time usage [h]
$t_e$	Emergency lighting charge time [h]
$t_N$	Non-daylight time usage [h]
$t_o$	Annual operating time [h]

$t_p$	Operating time of the parasitic power [h]
$t_s$	Scene setting operating time [h]
$t_y$	Standard year time [h](8760 h)
$w_{At}$	Width of atrium or courtyard [m]
$w_{L,d}$	Well-depth index
$W$	Total annual energy used for lighting [kWh/year]
$W_t$	Total energy used for lighting [kWh]
$W_{L,t}$	Energy consumption used for illumination [kWh]
$W_L$	Annual lighting energy used [kWh/year]
$W_p$	Annual parasitic energy used [kWh/year]
$W_{P,t}$	Luminaire parasitic energy consumption [kWh]
$W_{setting}$	Total input power of all luminaires forming part of the envisaged setting [W]
$\gamma_{site}$	Latitude angle of building location [°]
$\gamma_w$	Slope angle from horizontal of solid rooflight frame[°]
$\gamma_F$	Slope angle from horizontal of glazed rooflight [°]
$\gamma_{O,OB}$	Obstruction angle from horizontal [°]
$\gamma_{O,VF}$	Vertical fin angle [°]

**Annex ZA**  
(informative)

**Relationship between this European Standard and the Essential Requirements of EU Directive 2002/91/EC of THE EUROPEAN PARLIAMENT AND OF THE COUNCIL of 16 December 2002 on the energy performance of buildings**

This European Standard has been prepared under mandate M 343 given to CEN by the European Commission to provide a means of conforming to Essential Requirements of the New Approach Directive 2002/91/EC OF THE EUROPEAN PARLIAMENT AND OF THE COUNCIL OF 16 December 2002 on the energy performance of buildings.

Once this standard is cited in the Official Journal of the European Communities under that Directive and has been implemented as a national standard in at least one Member State, compliance with the normative clauses of this standard confers, within the limits of the scope of this standard, a presumption of conformity with the relevant Essential Requirements of that Directive and associated EFTA regulations.

**WARNING** — Other requirements and other EU Directives may be applicable to the product(s) falling within the scope of this standard.

## Bibliography

- GIL 65, Action Energy, 204 Metering use in non-domestic buildings.
- CIE Publication 158-2004. Ocular lighting effects on human physiology and behaviour.
- IEC 60050-845/CIE 17.4, International lighting vocabulary.
- EN 12665, *Light and lighting — Basic terms and criteria for specifying lighting requirements*.
- CIE 97: 2005, *Guide on the maintenance of indoor electric lighting systems*.
- CIE SO11: 2003, *Special distribution of daylight — CIE Standard general sky*.

## Further reading

- Chartered Institution of Building Services Engineers. *'Daylighting and window design'* Lighting Guide 10, London, CIBSE, 1999.
- Bell J and Burt W *'Designing buildings for daylight'* BRE report. Garston, CRC, 1995.
- Littlefair P J and Aizlewood M, *'Daylight in atrium buildings'* BRE information paper IP3/98, CRC, Garston, 1998.
- Littlefair P J, *'Site layout planning for daylight and sunlight; a guide to good practice'* BRE report, CRC, Garston, 1992.
- Littlefair P J, *'Selecting lighting controls'* BRE Digest 498, 2006.
- Littlefair P J. *'Daylighting design for display screen equipment'*. BRE Information Paper IP10/95. Garston, CRC, 1995.
- Littlefair P J *'Photoelectric control of lighting, design, setup and installation aspects'* Building Research Establishment Information Paper IP2/99. Garston, CRC, 1999.
- Littlefair P J. *'Designing with innovative daylighting'*. BRE Report BR 305. Garston, CRC, 1996.
- M Fontoynt (ed) *'Daylight performance of buildings'* James and James, London, 1998.
- Littlefair P J, *'Average daylight factor: a simple basis for daylight design'* Building Research Establishment Information Paper 15/88. (Garston, BRE, 1988).
- Tregenza, P R *'Mean daylight illuminance in rooms facing sunlit streets'* Bldg & Environ 30 (1) 83-89, 1995.
- Baker N, Fanchiotti A and Steemers K (eds) *'Daylighting in architecture'* James & James, London, 1993.
- BRECSU for Department of the Environment *'Electric lighting controls – a guide for designers, installers and users'* Good Practice Guide 160, BRECSU, Garston, 1997.
- Hunt D R G, *'The use of artificial lighting in relation to daylight levels and occupancy'* Bldg & Environ 14 (1) 21-33, 1979.
- Hunt D R G. *'Predicting lighting use - a method based upon observed patterns of behaviour'* Ltg Res & Technol 12 (1) 7-14, 1980.
- Littlefair PJ (1990), *'Predicting annual lighting use in daylit buildings'* Building and Environment **25** (1) 43-54.

Lynes JA and Littlefair PJ (1990), 'Lighting energy savings from daylight: estimation at the sketch design stage' Lighting Research and Technology **22** (3) 129-137.

David, R.; de Boer, J.; Erhorn, H.; Reiß, J.; Rouvel, R; Schiller, H.; Weiß, N.; Wenning, M.: Heizen, Kühlen, Belüften und Beleuchten, Bilanzierungsgrundlagen zur DIN V 18599. Fraunhofer IRB Verlag, Stuttgart (2006).

de Boer, J.; Erhorn, H.: *Ein einfaches Modell zur Klassifizierung der Tageslichtversorgung von Innenräumen mit vertikalen Fassaden.* gi Gesundheits-ingenieur 125, H. 6, S. 281-295.

de Boer, J.; Cornelius, W.; Wössner, S.: *Ein einfaches Modell zur Ermittlung des Endenergiebedarfs für Beleuchtungszwecke in Räumen mit Dachoberlichtern.* gi Gesundheits-ingenieur 126, H. 3, S. 113-123.

MR/ES  
060802